

OPEN ACCESS



# Educational Research and Reviews

August 2021  
ISSN: 1990-3839  
DOI: 10.5897/ERR  
[www.academicjournals.org](http://www.academicjournals.org)



**ACADEMIC  
JOURNALS**  
expand your knowledge

# About ERR

Educational Research and Reviews (ERR) is a peer reviewed open access journal. The journal commenced publication in April 2006. Educational Research and Reviews covers all areas of education such as comparative education, early childhood education, adult education, special education, teachers' training, vocational education, educational technology, educational administration and management, curriculum development, education policies and management.

## Indexing

[ERIC - Education Resources Information Center](#), [Google Scholar](#), [CNKI Scholar](#)  
[ResearchGate](#)

## Open Access Policy

Open Access is a publication model that enables the dissemination of research articles to the global community without any form of restriction. All articles published under open access can be accessed by anyone with internet connection.

Educational Research and Reviews is an Open Access journal. Abstracts and full texts of all articles published in this journal are freely accessible to everyone immediately after publication without any form of restriction.

## Article License

All articles published by Educational Research and Reviews are licensed under the [Creative Commons Attribution 4.0 International License](#). This permits anyone to copy, redistribute, remix, transmit and adapt the work provided the original work and source is appropriately cited. Citation should include the article DOI. The article license is displayed on the abstract page the following statement:

This article is published under the terms of the [Creative Commons Attribution License 4.0](#)

Please refer to <https://creativecommons.org/licenses/by/4.0/legalcode> for details about [Creative Commons Attribution License 4.0](#)

## **Article Copyright**

When an article is published by in the Educational Research and Reviews, the author(s) of the article retain the copyright of article. Author(s) may republish the article as part of a book or other materials. When reusing a published article, author(s) should; Cite the original source of the publication when reusing the article. i.e. cite that the article was originally published in the African Journal of Biotechnology. Include the article DOI Accept that the article remains published by the African Journal of Biotechnology (except in occasion of a retraction of the article). The article is licensed under the Creative Commons Attribution 4.0 International License.

A copyright statement is stated in the abstract page of each article. The following statement is an example of a copyright statement on an abstract page.

Copyright ©2016 Author(s) retains the copyright of this article.

## **Self-Archiving Policy**

The journal permits and encourage authors to archive any version of their article they find most suitable, including the published version on their institutional repository and any other suitable website.

## **Digital Archiving Policy**

Educational Research and Reviews is committed to the long-term preservation of its content. All articles published by the journal are preserved by Portico. In addition, the journal encourages authors to archive the published version of their articles on their institutional repositories and as well as other appropriate websites.

## **Metadata Harvesting**

Educational Research and Reviews encourages metadata harvesting of all its content. The journal fully supports the Open Archives Initiative.

# Memberships and Standards



Academic Journals strongly supports the Open Access initiative. Abstracts and full texts of all articles published by Academic Journals are freely accessible to everyone immediately after publication.



All articles published by Academic Journals are licensed under the [Creative Commons Attribution 4.0 International License \(CC BY 4.0\)](#). This permits anyone to copy, redistribute, remix, transmit and adapt the work provided the original work and source is appropriately cited.



[Crossref](#) is an association of scholarly publishers that developed Digital Object Identification (DOI) system for the unique identification published materials. Academic Journals is a member of Crossref and uses the DOI system. All articles published by Academic Journals are issued DOI.

[Similarity Check](#) powered by iThenticate is an initiative started by CrossRef to help its members actively engage in efforts to prevent scholarly and professional plagiarism. Academic Journals is a member of Similarity Check.

[CrossRef Cited-by](#) Linking (formerly Forward Linking) is a service that allows you to discover how your publications are being cited and to incorporate that information into your online publication platform. Academic Journals is a member of [CrossRef Cited-by](#).



Academic Journals is a member of the [International Digital Publishing Forum \(IDPF\)](#). The IDPF is the global trade and standards organization dedicated to the development and promotion of electronic publishing and content consumption.

## Contact

Editorial Office: [err@academicjournals.org](mailto:err@academicjournals.org)

Help Desk: [helpdesk@academicjournals.org](mailto:helpdesk@academicjournals.org)

Website: <http://www.academicjournals.org/journal/ERR>

Submit manuscript online <http://ms.academicjournals.org>

Academic Journals  
73023 Victoria Island, Lagos, Nigeria  
ICEA Building, 17th Floor,  
Kenyatta Avenue, Nairobi, Kenya.

## **Editors**

### **Dr. Peter W. Wong**

Southern Cross University  
Australia.

### **Dr. Jean Madsen**

Department of Education Administration and  
Human Resource and Development,  
Texas A&M University,  
United States

## **Associate Editors**

### **Dr. Melissa Vick**

School Of Education  
James Cook University  
Townsville,  
Australia.

### **Dr. Laima Kyburiene**

Kedainiai Jonusas Radvila Study Center  
Kauno kolegija/University of Applied  
Sciences  
Lithuania.

### **Dr. Mustafa Çakir**

Secondary Science and Mathematics  
Education,  
Marmara University  
Turkey.

### **Dr. Alexandru-Constantin Strunga**

Department of Communication, Journalism  
and Education Sciences  
University of Craiova,  
Romania.

### **Assoc. Prof. Manjula Vithanapathirana**

Faculty of Education  
University of Colombo  
Colombo,  
Sri Lanka.

### **Dr. Tolga Gök**

Torbali Vocational School of Higher Education  
Dokuz Eylul University  
Izmir,  
Turkey.

### **Prof. Ogunsakin R. Ebenezer**

Department of Statistics  
Ekiti State University  
Ado Ekiti,  
Nigeria.

### **Dr. A. Kadir Maskan**

Dicle University  
Ziya Gokalp Education Faculty  
Department of Physics Education  
Diyarbakir,  
Turkey.

### **Dr. Kamo Chilingaryan**

Foreign Languages,  
Law Institute at Peoples' Friendship University,  
Russian Federation.

### **Dr. Maniam Kaliannan**

Faculty of Administrative Science & Policy  
Studies  
Universiti Teknologi MARA (UiTM)  
Selangor,  
Malaysia

### **Dr. Tavis D. Jules**

Cultural and Educational Policy Studies  
School of Education  
Loyola University Chicago  
Chicago,  
USA.

## **Editorial Board**

### **Prof. García Mayo, María del Pilar**

Departamento de Filología Inglesa y Alemana y  
de Traducción e Interpretación  
Universidad del País Vasco (UPV/EHU)  
Paseo de la Universidad 5  
Vitoria,  
Spain.

### **Prof. Georgios D. Sideridis**

University of Crete  
Department of Psychology  
Rethimno,  
Greece.

### **Dr. Işıl Aktağ**

Physical Education Teaching,  
Bolu Abant İzzet Baysal University,  
Turkey.

### **Prof. Mutendwahothe Walter Lumadi**

Curriculum & Instructional Studies  
College of Education  
UNISA,  
South Africa.

### **Prof. Moshe Barak**

Graduate Program for Science and Technology  
Education  
Ben-Gurion University of the Negev,  
Beer Sheva,  
Israel.

### **Dr. Hiam Zein**

Psychology and Education  
Lebanese American University  
Chouran-Beirut,  
Lebanon.

### **Prof. Bingjun Yang**

School of Foreign Languages  
Southwest University  
Chongqing,  
China.

### **Dr. Ernest W. Brewer**

The University of Tennessee  
Educational Administration and Supervision  
Tennessee,  
USA.

### **Prof. Gail Derrick**

Regent University  
School of Education  
Virginia Beach,  
USA.

### **Dr. Evridiki Zachopoulou**

Department of Early Childhood Care and  
Education  
Thessaloniki,  
Greece.

### **Dr. Syed Iftikhar Hussain Shah**

Technical Education and Vocation  
TEVTA Secretariat  
Lahore,  
Pakistan.

### **Dr. Ravi Kant**

College of Teacher Education  
Maulana Azad National Urdu University  
Darbhanga,  
India.

## **Editorial Board**

### **Dr. Dibakar Sarangi**

Directorate of Teacher Education and State  
Council for Educational Research and Training  
(DTE & SCERT)  
Odisha,  
India.

### **Dr. Mehmet Akif Sözer**

Department of Primary Education  
Gazi Faculty of Education  
Gazi University  
Turkey.

### **Dr. Georgios Bikos**

School of Humanities  
Hellenic Open University  
Greece.

### **Dr. Cemil Inan**

Department of Primary Education  
Ziya Gökalp Education Faculty  
Dicle University,  
Turkey.

### **Dr. Mehmet Demir**

Department of Administrative and Policy Studies  
School of Education  
University of Pittsburgh,  
USA.

### **Associate Prof. Abdulsalam Al-Hadabi**

Curricula and Ped  
agogy, Amran University,  
Yemen



## Table of Content

<b>Teaching of a volleyball technique and representations of physical education teachers in Sub-Saharan African environment</b>	325
Fernandes Balou Gabin, Lembe Gorgon, Ambeto Aimé Simplicie Christophe and Itoua Okemba Jean	
<b>Scholars and educational positions under criticism and praise in the Medieval Islamic Era</b>	336
Hatim Muhammad Mahamid and Younis Fareed Abu Al-Haija	
<b>The discovery teaching of the problem of finding the shortest distance with the help of Geogebra software in Vietnam</b>	343
Ngoc-Giang Nguyen	
<b>Visually supported activity suggestions to develop secondary school students' story writing skills</b>	357
Soyuçok Mehmet and Musa Çifci	
<b>The theoretical analysis of ethical leadership lapses: A disturbing concern about school leadership in Botswana</b>	372
Nkobi Owen Pansiri, Chikezie Ignatius Ugwu and Wazha Bickie Maundeni	

*Full Length Research Paper*

# Teaching of a volleyball technique and representations of physical education teachers in Sub-Saharan African environment

**Fernandes Balou Gabin<sup>1,2\*</sup>, Lembe Gorgon<sup>1</sup>, Ambeto Aimé Simplicie Christophe<sup>1,2</sup> and Itoua Okemba Jean<sup>1</sup>**

<sup>1</sup>Laboratory of Didactics of Physical Education, Higher Institute of Physical Education and Sports, Marien NGOUABI University, Brazzaville, Republic of Congo.

<sup>2</sup>UNESCO Chair in Educational Sciences, Ecole Normale Supérieure, University Marien NGOUABI, Brazzaville, Republic of Congo.

Received 11 May 2021; Accepted 26 July 2021

The purpose of this study is to identify and analyze, based on representations of physical education teachers, the obstacles to teaching of cuff volleyball in middle schools in Brazzaville, Congo. The theoretical model of Trinquier's representations, which is based on the "attitude" variable as an evaluative judgment variable, made it possible to distinguish the attitudes of teachers and to characterize this population in terms of representations, and therefore sociological anchors. A total of 86 physical education teachers responded to a questionnaire, and 18 structured and intensive interviews were carried out. These were addressed using categorical content analysis. Subsequently, classical statistical indices (numbers, percentages, confidence interval), chi-square test and multinomial regression analysis were used to analyze the attitudes observed on teachers. The results show that the lack of time, material and space, the plethora of effectives in classes, the specific perceptions to socio-professional, motivational, ecological and didactic variables, represent pedagogical misunderstandings by hampering the teaching process of this technical gesture. Thus, our data reveal the need to promote new methods of teaching volleyball cuff, contextualized in Negro African environment.

**Key words:** Physical education, teachers, cuff, representations, volleyball.

## INTRODUCTION

In Congo, Physical Education (PE) is a teaching discipline of the education system. This school discipline uses Physical Activities and Sports (PAS) teaching to

develop collectively and individually. Nowadays, team sports are the most popular among schoolchildren. Their teaching interests researchers in the field of Sciences

\*Corresponding author. E-mail: ferbalou@gmail.com. Tel : +242 064933077.

and Techniques of PAS (STPAS) (Gréhaigne, 1992). Formerly used in sports animation to manage the recurring problem of overcrowding pupils of classes in sub-Saharan Africa (Ogueboule, 1999), team sports today have a physical education content to be taught and defined by study grade (Atoun et al., 2018a; INRAP, 2005). The designed curricula give precedence to the pupil, who is immediately placed in core of the construction of his own knowledge (Atoun et al., 2018b). The aim of team sports teaching is two-fold: to train a technically and humanly balanced, efficient citizen; and to contribute to human development (Attiklémè, 2009). With reference to several studies on team sports, their teaching is based on the correct achievement of specific motor skills (Gréhaigne, 1992), focused on the learner and on the game (Poussin et al., 2014; Gréhaigne et al., 1999). Teaching of team sports in physical education, by subscribing to this logic, makes operational this established purpose of the scholar curricula. Team sports present privileged spaces for the selection and production, as well as transformation and transposition, then transmission of values, knowledge, and skills to school audiences (Backman and Barker, 2020; Klein, 2003 in Attiklémè and Kpazai, 2011: 84). Among these team sports, volleyball, which is a physical activity of cooperation characterized by opposition of players, was selected. Volleyball teaching serves as a means of intellectual and physical education as well as social integration (Amans-Passaga and Verscheure, 2020; Silva et al., 2020). However, in subsaharan Africa volleyball is scarcely taught because it is a high-performance activity which presents several difficulties in its practice and in its teaching (Atoun et al., 2018a). It is particularly one of the most difficult team sports to teach (Oguéboulé, 1999). This high-stakes game links technical, tactical, physical and mental aspects in a temporal urgency context, imposing speed of reaction and gestural automation. This situation creates constraints which influence the teaching practice of the class grade; its teaching in the middle schools thus remains a problem. Several reasons seem to justify this observation. First, volleyball involves highly technical knowledge of teachers, and two technical dexterity, scientific and professional knowledge (Terrisse, 2001; Lepuissant, 2016). Second, the logistical difficulties and the plethora of class sizes add to the score without forgetting some socio-professional factors (Atoun et al., 2018b). It is therefore in this gloomy context that the teaching of volleyball cuff takes place in middle schools in the Republic of Congo.

### **Aim of the research**

It emerges from our experience as a physical education teacher, from our observations and from the reports of national conferences on the teaching of physical education, that volleyball is hardly practiced in Congo,

and it is scarcely taught in the majority of establishments of the interland. The teachers, without well-off in knowledge, higher acquired knowledge and know-how in this practice avoid the teaching of cuff, fundamental technical gesture in the practice of volleyball. In addition, we note the existence of the perception of "legitimate" competence (Bourdieu, 1980) among Congolese teachers of physical education. In other words, there appears to be a potential insufficiency in the recognition of "statutory competence" (Bourdieu, 2006) in the implementation of volleyball lessons focused on cuff's teaching in schools, especially in middle school where this sport is taught for the first time. This lack of competence which is internalized influences its realization within the class. Therefore, it seems that in order to establish "pedagogical competence", most teachers rely on individual strategies that are not very sustainable. It is in this sense that these lines of thought deserve further exploration in the light of the theoretical model of Trinquier (2011) on representations, among the consensual elements, that attitude constitute the central core of representation as an "evaluative element". It participates in sociological anchoring via the process of "meaning assignment". Operator of contextualization, the representation of the cuff's teaching on physical education teachers refers to teaching conditions perceived as facilitating, restrictive, or without effect on the action.

Thus, the conditions evoked by these can be of the following types: macrosocial (it means that society allows teachers to exercise their profession); mesosocial (type of student population in relation to the geographic location of the school in which they practice); microsocial relating to the classroom situation (classroom climate, student reactions). All of this underlines the need to test the relationship between the situations of cuff's teaching in Congolese physical education teachers and their practices, through their experiences, the typologies of practices and the didactic positioning. The purpose of this study is to identify and analyze the representations that physical education teachers make and their effects in the teaching / learning process of the cuff. To study this problem, we started from a main question formulated as follows: Do the representations of physical education teachers influence the teaching / learning process of the volleyball cuff? From this main question arise the following secondary questions: What are teachers' representations of the teaching of volleyball cuff in middle schools and how are they structured? To answer these questions, we hypothesized that: teachers' representations of the volleyball cuff depend on the motivational, socio-professional and pedagogical factors which are associated with the assigned tasks. To do this, questionnaires intended for physical education teachers and interviews were conducted with other teachers in order to provide information on, the kind of the evoked representations and the relationships between the representations and the declared practices.

**Table 1.** Distribution of physical education teachers during survey.

Variable	Female n (%)	Male n (%)	Total n (%)
Makélékélé's SISPE	4(44.5)	5(55.5)	9(8.0)
Bacongo's SISPE	13(81.2)	3(18.3)	16(14.3)
Poto-Poto's SISPE	3(50)	3(50)	6(5.4)
Moungali's SISPE	6(54.5)	5(45.5)	11(9.8)
Ouenzé's SISPE	4(36.4)	7(63.6)	11(9.8)
Talanga's SISPE	8(61.5)	5(38.5)	13(11.6)
Mfilou's SISPE	5(55.5)	4(44.5)	9(8.0)
Madibou's SISPE	6(75.0)	2(25.0)	8(7.1)
Djiri's SISPE	5(50.0)	5(50)	10(8.9)
Mbamou isle	0(0.0)	1(10.0)	1(1.0)
Specialized schools	8(44.4)	10(55.6)	18(16.9)
Total	62(55.4)	50(44.6)	112(100)

SISPE: Sectorial inspectorate of sports and physical education.

## MATERIALS AND METHODS

### Research model

The mode of investigation was based on a mixed approach (for example, qualitative and quantitative), on the basis of a cross-sectional survey. To assess teachers' representations structure of cuff's volleyball, questionnaire and interview were used. For Abric (1997), this instrument is one of the most used in the sciences of education, because it does not require any limitation on "the expression of the respondent to the strict questions that are proposed to him", particularly through the use of items or questions evocation. According to the author, the recent development of data analysis methods applied to education reinforces the privileged position of the questionnaire. With regard to interviews, these are techniques very often used to collect opinions, beliefs, ideas and attitudes concerning various social objects (Molinier et al., 2007). The adoption on an approach of triangulation of qualitative and quantitative methods which is applied to our study, relates to works linked to representations of teachers (Moldoveanu et al., 2016). The study was conducted between July 6 and 30, 2018 in Brazzaville (capital of the Republic of Congo). The population of this city is estimated at 1,838,348 inhabitants, of which 573,416 (31.2%) are pupils of the secondary education (CNSEE, 2021). Interestingly, we want explore the representational domain through professional practices and their relationship to knowledge. Therefore, this research is part of a comprehensive policy for physical education teaching in Congo, taking into account the physical and social environment conducive to activities, collective activity programs and physical and sporting activities.

### Sampling and respondents

The population of this study was 112 physical education teachers working in public middle schools administered by the nine (9) sectoral inspections of sports and physical education (SISPE) and specialized directorates of the city of Brazzaville (Table 1). The inclusion criteria for subjects were: written consent to participate in the study; seniority in the physical education teaching at least 3 years; experience in physical education teaching in the third year; exercise of the of physical education teaching in a middle school during the period of study. At the end of the sampling operations, 94 teachers were selected and took part in the study. These were

54 women (57.4%) and 40 men (42.6%). They worked in 18 general education middle schools and 3 technical education middle schools in Brazzaville.

### Experimental protocol and design

The questionnaire, by its standardization, was chosen in order to reduce both the subjective risks of data collection (standardized behavior of the interviewer) and the inter-individual variations in the expression of subjects (standardization of the expression of respondents: same questions for all subjects, same award conditions, do not always require the intervention of survey manager). It was chosen for its ease of use and its standardized nature. The questionnaire, consisting of 9 questions, aimed to collect factual information on the attitudes of teachers on volleyball cuff's teaching. It was structured in: closed questions, open questions, multiple choice questions. These made it possible to obtain precise answers (closed questions), to collect personal evocations (open questions), and to compare the opinions of the teachers with the proposed answers (multiple choice questions).

The questionnaire was structured in three parts. Part I, which contained 5 questions, focused on the identification of teachers (grade, gender, seniority in the exercise of physical education teaching, establishment, inspection and classes held). Part II consisted of 4 questions focused on sports preferences, volleyball programming in establishments, training, facilities and teaching materials. Part III concerned the teachers' comments on the didactic aspects of cuff's teaching in middle schools (pedagogical approach to receiving ball, observed difficulties, remediation of shortcomings while learning the cuff gesture). The questionnaire was distributed during the examination of Diploma of the Brevet d'Etudes du Premier Cycle (equivalent to General Certificate of Education Ordinary level, GCE"O" level), July 2018 session. Finally, 86 questionnaires duly completed were collected.

The structured and intensive interviews made it possible to collect information concerning the opinions of teachers in their relation to knowledge of volleyball cuff (or professional knowledge). Duration of each interview took place between 45 min and 1 h. A total of 18 interviews were conducted using an Enet@M50 Digital Voice Recorder branded didactophone, China (Recording time: 15,160 min; frequency: 16 KHz). These directive and intensive interviews were carried out without video support, because we wanted to collect the familiar actions spontaneously recalled in

memory. Examples of questions asked: How do you feel about teaching the volleyball cuff? Is it difficult or not? Why? Have you realized it already? Do you think you will achieve it? The analysis of these 18 interviews aimed to identify among the representations evoked by the teachers about their behavior and their attitudes (representations describing the practices and justifying them) those having a generic character, that is inter-individual manner with a majority of teachers.

Regarding the analysis of the scope and structure of the representation of the headline among teachers, firstly, PE teachers were asked to write down the first ten words that spontaneously came to them, and mind when they heard the word "headline". The function of this free association phase was to activate the field of representation, that is to say the elements of the content connected directly to the word stimulus. Secondly, each teacher had to deepen their memory research by giving five nouns, five verbs and five adjectives, the order of presentation of the request being randomized. In other words, it was to allow the teacher express, by nouns, the referents associated with the word "headline"; by verbs, behaviors related to the inducer; and by adjectives, value judgments. The search for stabilizing elements of attitudes observed among teachers, a Likert scale made it possible to measure the affective dimension of attitude using a semantic differentiator inspired by that of Osgood (Trinquier, 2011). It made it possible to characterize the attitude based on the characteristics given to the cuff, its degrees of power as well as the value judgment inspired by the mastery and execution of this technical gesture. Osgood's semantic differentiator uses the principle of verbal associative bonds mediated by a semantic impression, that is, a process of signification by which a verbal stimulus (a word in our study 1 represents a signified) is associated with a verbal response (another word with a positive or negative connotation). The connotation attributed to this second word reflects the emotional position (polarized or not) of the teacher vis-à-vis the teaching of the headline; the evaluative dimension, which is attached to social representation (Moliner et al., 2007), participates in anchoring via the process of "meaning assignment".

### Data analysis

The content analysis of the data collected was carried out in three stages: transcription of all recorded interviews; condensation of the transcribed data; qualitative analysis of the content of collected data. For this, the interviews with the teachers were treated qualitatively from a thematic analysis. Thus, we took into consideration the analysis of each speech proposed to account for the personal and institutional relationship to teachers' knowledge. Primary data analysis and initial analysis of the data collected, helped make sense of the data collected to answer research questions and test the hypothesis that a study is initially supposed to assess. It should be noted here that in our text, first names were included in the interview report. These are included for illustrative purposes only, in no way revealing the identities of the surveys. Descriptive (univariate) and inferential (bivariate and multivariate) statistics were used to analyze the data obtained. Results are presented as numbers and percentages for qualitative data. The level of internal consistency of the questions has been checked. It was estimated from Cronbach's  $\alpha$  index, which is considered acceptable for values ranging from 0.62 to 0.87 (Crocker and Algina, 1986): its value was 0.84 to 95% for a confidence interval (CI) of 0.83-0.88. In this study, chi-square ( $\chi^2$ ) test was used as a test of association; it was applied to determine the association between the included variables. This is a test to determine whether or not there are relationships between the perception of the achievement of the cuff and the adoption of an appropriate attitude, as well as between the determinants of the implementation of an appropriate teaching program in the cuff. In other words, chi-square

test was used to determine whether there is an association between the variables included in the theoretical model. Finally, multinomial logistic regression was used to find out how the level of initial training, duration in the exercise of physical education teaching, and some pedagogical variables could influence the implementation of cuff's teaching.  $p \leq 0.05$  defined statistical significance. All statistical analyses were performed with SPSS for Windows version 25.0, at the Laboratory of Statistics and Numerical Analysis of Faculty of Sciences and Technology, Marien Nguoubi University.

## RESULTS

### Questionnaire data

Analysis of the data collected reports that volleyball was scheduled in 24.7% of cases. The reasons for non-programming in schools were: lack of teaching material (net, ball, etc.), space and overcrowding. The distribution of respondents according to the sports specialty chosen during the last year of academic season at the Higher Teaching of Physical Education Institute is shown in Table 2.

The data in Table 3 show that, according to the teachers' comments, the main obstacles to volleyball cuff's teaching are the excessive effectives of classes, the lack of apparatus and other materials of volleyball practice, the lack of space, and the perceptions of the pupils. Among the other obstacles, the difficulty of the pupils to reach the return the ball following the effects of ball during the realization of the headline was cited. Moreover, the logistic analysis of the interaction of initial training's level on the achievement of cuff teaching during a volleyball sequence (Table 4) reveals that there is a significant difference between the of initial training levels (CAPAEPS versus CAPEPS and / or Master EPS) and the realization of cuff teaching.

The other results of the logistic analysis is concerned with the interaction between, on the one hand, seniority in the exercise of physical education teaching and the achievement of a cuff's teaching during a volleyball sequence (Table 5) and on the other hand, the implementation of the volleyball teaching and some educational variables (Table 6). It emerges from these data tables that: the duration in the exercise of physical education teaching is a determining factor in the achievement of cuff teaching; cuff's teaching is dependent on the teacher's post-IT specialty, field, teaching materials, and class size.

### Corpus of teachers' entretienings

The most significant representation put forward by 7 female teachers questioned out of 9 of the same sex working in middle school concerns the difference in sex with respect to their pupils, which is systematically taken into consideration in the management of the class. This presupposes, on the part of teachers, gendered

**Table 2.** Distribution of respondents according to the sports specialty in physical education.

Variable	Effective	%
Volleyball	25	29
Athletics	17	20
Basketball	16	18
Gymnastics	15	17
Judo	13	16
Total	86	100

**Table 3.** Results of the tests of association of the achievement of a teaching of volleyball cuff and the perceived obstacles.

Variable	Chi-square value	P
Lack of time	2.12	0.06
Lack of material	9.91	0.000
Lack of space	3.86	0.04
Bloated workforce	28.75	0.000
Student perception	3.61	0.000
Other obstacles	49.29	0.000

**Table 4.** Logistic analysis of the interaction of the level of initial training on the realization of cuff teaching during volleyball sequence.

Variable	B	SE	exp (B)	P	IC(95%) for exp (B)	
					Lower limit	Upper limit
CAPAEPS	0.664	0.525	1.942	0.206	0.875	3.012
CAPEPS and/Master	1.512	0.547	4.535	0.006	1.521	7.681
Carrying out a cuff teaching	2.185	0.689	8.893	0.002	2.402	11.676
Initial training x realization of a cuff teaching	-0.630	0.259	0.533	0.015	0.393	0.816

CI: Confidence interval; CAPAEPS: Certificate of aptitude for assistant professor of physical education; in middle schools; CAPEPS: Certificate of aptitude for professor of physical education in middle schools and high schools.

**Table 5.** Logistic analysis of the interaction of seniority in the physical education teaching and the achievement of cuff teaching during a volleyball sequence.

Variable	B	SE	Exp (B)	p	CI (95%) for exp (B)	
					Lower limit	Upper limit
10 years ≤ seniority ≤ 20 years	0.322	0.087	1.380	0.000	1.164	1.637
Seniority > 20 years	0.601	0.174	1.825	0.001	1.299	2.564
Carrying out a cuff teaching	-1.012	0.540	0.363	0.061	0.126	1.047
Duration in the profession x completion of a cuff teaching	0.626	0.318	1.871	0.049	1.003	3.490

representations of pupils as well as interpretations of social behavior and interactions based on a gendered reading grid. For example, for Rose, a PE teacher for 7 years in a technical middle school with little mixed streams, some made up mostly of boys, others mostly of

girls, it would be heterosexual seduction that influences the relationship with pupils:

*"I think in my middle school, it's easier to be a woman, because for my male colleagues, it's more difficult to*

**Table 6.** Logistic analysis of the interaction between the implementation of the cuff teaching and some pedagogical variables.

Variable	B	SE	Exp(B)	P	CI 95% for exp (B)	
					Lower limit	Upper limit
Post-IT specialty	0.322	0.087	1.380	0.000	1.164	1.637
Coach of a volleyball team	0.046	0.503	1.047	0.927	0.391	2.805
Programming	-0.104	0.289	0.901	0.718	0.512	1.587
Ground	0.601	0.174	1.825	0.001	1.299	2.564
Teaching materials	-1.012	0.540	0.363	0,041	0.126	1.047
Workforce	0.626	0.318	1.871	0,029	1.003	3.490

FI: Initial training; CI: Confidence interval.

*perform the volleyball cuff. The girls are really, in quotes, in seduction".*

Sex is not necessarily perceived as a disadvantage for the teacher to teach this gesture, although it is here "the girls" who are perceived as "the problem". At the same time, the same teachers spoke of the difficulties experienced in winning at the start of the scholar year in front of classes made up exclusively of boys:

*"For my first job, I was in an almost 100% male establishment. [...]. First job, I was a little lost and ... I had a class recomposed between secretary, accountancy, electricity, masonry and mechanics, restoration and mechanics: explosive! And ... this is a class that I had a hard time asserting myself with. Besides, I didn't have a lot of years behind them".*

If previously, Rose insisted on the ("easier") advantage of being a woman in her school, in this excerpt she evokes her difficulty in establishing herself among a group of pupils qualified as "100% male" from several specific fields, and with whom she considers that she has little difference in age.

Sandra, another physical education teacher in an industrial technical middle school, also underlined a difficulty in asserting herself with a class mainly composed of boys:

*"it is very difficult for me to adapt to such turbulent students and, moreover, only boys, since we only have boys in middle school [...]. I have not yet found the solution to succeed in channeling them".*

As Rose, pupils' deviant behaviors are perceived to be exacerbated because of their gender. She extends this interpretation of the link between sex and its difficulty, by postulating that the latter is shared by the pupils. She expresses herself by putting herself in their shoes:

*"Wow! Is she the teacher? Have you seen the teacher? It's her!" And there, I said to myself: "Wow! It's going to be hard!" Because they're like, "Oh yeah! She's a young*

*woman, she's a woman; we are just guys, it's going to be good for her! It'll be nice!" [Ironic attitude]".*

Sandra will eventually succeed in establishing herself in class and teaching the cuff despite initial apprehensions related to these reports and representations:

*"Even though I'm a woman, it's going very well [...] it isn't of disadvantage, in quotes, to be a woman in front of a male audience."*

The testimony of Aurélie, physical education teacher in a middle school, also explains the level of difficulty or ease in imposing authority through social relations of sex, although her interpretation of this link differs from that of Sandra:

*"There were mixed classes with whom it was going well. On the other hand, the classes of boys, it was very difficult to manage [...] for a woman".*

Aurélie then pays attention to her professional outfits and to her language register with the pupils in order to recall her institutional status as a teacher who legitimizes her authority:

*"I have always dressed ... [...] never a dress and never a skirt in the establishment. Never a cleavage. [...] Especially in relation to boys. I called myself: "madam" instead of "mademoiselle" also, that already poses [...] a distance".*

Nevertheless, Aurélie also points out difficulties with pupils of the same sex. She talks about it in these terms:

*"There is the difference in sex. I think a boy ... well we both had problems: him, as a man, he had conflicts with boys. I, as a woman, had conflicts with, in fact, the girls".*

Finally for Isabelle, a physical education teacher with 5 years seniority in the profession, it would rather be the origins that overlap with sex relations to make it more or less difficult to impose their authority in the

implementation of teaching / learning this gesture:

*"And then, it's a mixture of cultures and origins too, that means that not everyone has the same view of things. There are still pupils from other African countries, who for them ... women are nothing, in quotes, and therefore, who have difficulty understanding authority. Suddenly, there were, all the same, a lot of clashes. What made me relate was that it was not just with me, but with other colleagues as well, young female teachers, with whom it was difficult. [...] So, the classes are quite difficult, in general, but there is one which is particularly unlivable and very difficult, which is resistant to authority in general, but even more so to female authority. And, I'm not the only one, eh! Several colleagues from the teaching team with this class have had a lot of problems at the start of their profession, just to show authority".*

Thus, for this almost beginner teacher, the difficulties in imposing her authority over an audience of male pupils are perceived as being linked to a combination of factors, gender and "cultures" or "origins".

## DISCUSSION

The questionnaire data show that the cuff teaching during a volleyball sequence was achieved by only 18.6% of teachers who opted for volleyball as a specialty in team sports in initial training; the main motivational factors for not performing this activity were an unpleasant gesture, a restrictive technique, fear of failure, lack of mastery of gestures, problems with contact with the ball, complexity of gestures, and poor achievements in initial training. These results confirm our hypothesis which states that: teachers' representations of the volleyball cuff: teaching depends on the motivational, socio-professional and pedagogical factors which were associated with assigned tasks. Our observations show that the teaching of volleyball is not regularly provided in accordance with the official texts, particularly decree n° 84/581 of June 20, 1984, making compulsory the organization and the practice of physical education in all sequences of physical education in the Republic of Congo. Volleyball was to be taught in middle school in 6th and 3rd year classes (INRAP, 2005). Indeed, the development of the annual programming of PAS in schools is developed either by the coordinator (head of department) or by Educational Research Groups (ERG-PE) depending on the school. The ERG within an educational establishment is called upon initially, to observe the institutional prescriptions (respect of program book) by developing pedagogical strategies, which take into account the activities selected by the State on the one hand and by putting in place of procedures and knowledge, used in didactic research to build skills. This approach goes hand in hand with the official instructions (OI) of the Republic of

Congo which stipulate that the annual programming must be established at the behest of the coordinator and by all teachers who are jointly responsible. Without underestimating the difficulties encountered in the collective development of such a document, it is necessary to establish it on the basis of the official program, program of sports events, state examinations and material conditions (sports facilities, small equipment, etc.) (OI,1970). Therefore, the programs should have a strong professionalizing dimension with training content focused on the process of transmission-appropriation of practical knowledge (Romar and Ferry, 2019). Following this, Gil-Arias et al. (2021) suggested that physical education programs must demonstrate the presence of didactic skills, and promote the products trained to design and animate teaching situations. In reality, the programming of the PAS observed in the pedagogical documents of the respondents in the various establishments, was based on the availability of equipment. The link between quality of infrastructure and teaching of programmed PAS was found (Table 3), because schools did not have the necessary infrastructure and equipment appropriate to volleyball teaching, especially cuff training.

Results of the present study support the hypothesis that teacher's representations of volleyball cuff's teaching depend on the motivational, socioprofessional and pedagogical variables which were teacher's with assigned tasks. Regarding the motivational factors found, pleasure was one of them. In this regard, Haye (2012) thinks rather that in physical education, "pleasure is not a problem, only its absence is a problem" (Haye, op. cit.: 15-16). The words of this author show that the feeling of pleasure, which explains part of the motivation, is the effective way to give meaning to teaching. The displeasure of cuff teaching being found in 91.42% of the teachers, our observations consolidate the remarks of Haye (op.cit.), and those of Quennerstedt (2019) which testify to an essentially technicist conception of volleyball teaching, namely *"Teaching volleyball consists primarily of teaching subjects to perform basic technical gestures (pass, cuff, attack and serve, etc.)"*. Indeed, the basis of volleyball teaching is focused on learning the fundamentals (technical gestures). This is why the teacher has the obligation to mobilize, maintain the interest and motivation of the pupil in the field of task. Without losing sight of the goal to be achieved, the teacher makes it more pleasant to achieve with his help. It is in this perspective that Eloi (2000: 3) thinks that it is the quality of the representations (those that the subject has of the environment in which he makes but also those that the subject has of the environment in which he makes but also those of the action), which makes it possible or not to achieve the set goal.

Another obstacle for teachers is pupil's behavior. This is the behavior of the pupils, level of volleyball practice deemed insufficient, lack of time to keep pace with the learners, feeling of not knowing how to do otherwise and



management of pupil's behavior which is not facilitated during the cuff teaching. This fact is also found by Scrabis-Fletcher and Silverman (2017), Magendie and Bouthier (2013) among secondary school students. Thus, when we confront the observations with the reference theory of Trinquier, which argues that "the analysis of a representation, the understanding of its functioning necessarily requires a double identification: its content and its structure" (Trinquier, 2001:72). Thus, it is possible to suggest that the time devoted to cuff teaching is insufficient to promote the acquisition of fundamental gestures. Given the high effectives noted in the majority of classes in Congolese middle schools, one assumes that the practice time allotted to each learner is insufficient to ensure the acquisitions. This low rate of practice time available to learners is explained by the nature of activities retained by teachers during the volleyball sequences which are, centered on gymnastics and athletics, as Mviri points out (2018). During the observation of 42 physical education lessons, the author notes only 16 included sequences focused on volleyball and only 4 were assigned as cuff learning. However, the interpretation of reasons linked to valuation and devaluation mentioned by the teachers is difficult because this appreciation is subjective. In fact, we do not have access to the feelings of these, moreover, one with regard to the valuations; it would take an implication of pupils to find out whether it is automatic or thoughtful encouragement, the former not being credible on teachers. When we compare what is observed as the teachers' reasons for their actions, we note a Pygmalion effect (Al-Tawel and Al-Ja'afreh, 2017; Rosenthal and Jacobson, 1969). Physical education teachers who have low expectations of learners tend not to put in place pedagogical practices to deliver a course on their schools' cuff volleyball (Silva et al., 2020), thus reducing the chances of learning and learning. Finally, our physical education teachers have their own ability to teach this gesture.

Our results also showed that the physical education teachers who chose volleyball as an option during initial training constituted 18.6% of the total teachers who taught the cuff gesture (Table 2), notwithstanding their inclusion in the timetables, at the rate of two hours per session and twice a week. This suggests the intervention of teachers specializing in volleyball in schools in order to relieve non-specialists of this teaching, an approach which is not possible. However, we understand why the majority of these teachers were in favor of removing volleyball from the middle school curriculum due to poor learning. By the way, in Europe during PAS courses, pre-professionalization already confronts the supervisor with real situations coming into questioning more theoretical aspects of training (Backman and Barker, 2020; Milos et al., 2019). The transition to the status of trainee teacher from the first year of training in physical education teaching induces a complexity of process; by highlighting

a system of standards, it upsets certain conceptions of teaching and leads the trainees to build new knowledge, plural and combined in action (Sood Al-Oun and Shaddad Qutaishat, 2015), absence of practice of some PSAs by physical education teachers is a sad reality in Congo. However, according to Gil-Arias et al. (2021) it is by practicing PSAs that we build knowledge. Indeed, the training transmits often representations which can be in competition with the initial representations; it follows difficulties in terms of the acquisition of knowledge. While it is therefore undeniable that they are of capital importance, we cannot however hide some other parameters which will influence and participate in the own development of learning (Therriault et al., 2011).

Therefore, the concept of competence, often discussed, needs to be clarified. In our study, it takes place with the level of initial training (Table 4) and seniority in the teaching profession (Table 4). From a general point of view, De Ketele (1985) emphasizes its inclusive and finalized dimension. Competence, by updating in a complex practice and by mobilizing prior knowledge and know-how, transforms them and develops attitudes and skills to become, oriented towards the purposes of teaching. Perrenoud (1995) refines this definition by specifying that competence mobilizes heterogeneous cognitive resources: patterns of perception, thought and action, intuitions, values, representations, knowledge, etc. This set is combined in a problem-solving strategy at the cost of reasoning made up of inferences, anticipations, evaluation of possibilities and their probability of success. More specifically, during the teaching-learning process, the professional skills of teachers cover plural knowledge used in the planning, organization, and cognitive preparation of the session and in the practical experience resulting from interactions in the classroom. This knowledge is crossed by a strongly affective dimension (Ferry, 2018). Indeed, outside the presence of pupils, the teacher is led to question his own relationship to knowledge; within the framework of interactions in class, he must also manage the reactions of the group, anticipate possible drifts and distance himself from his own emotions when the situation particularly affects him. Finally, knowledge integrates a social dimension because, during the training process, exchanges with different actors (trainees, trainers, etc.) participate in professional construction. It is at this level that other types of knowledge (about and for action) are to be built for oneself and with others.

Thus, the achievement of the cuff teaching by teachers is dependent on the expectation of competence. It has been indicated for this purpose that in terms of self-knowledge, the feeling of competence or personal efficiency, "I can teach the gesture because I feel competent to carry it out" is an important component (Bandura, 1990). These elements reinforce the idea that the choice in teaching technical skills for our teachers is made on the basis of knowledge of their "representation

of competence". However, according to Connell et al. (1994), competent feeling in an activity would not be a determining factor in choosing a PSA. These comments reinforce those of Délignières and Garsault (1991): "the fact that a subject feels competent in an activity will certainly encourage him to continue it". The feeling of competence is thus considered as an important component among the determining factors in a choice education. Another reason of score sequences centered on cuff volleyball is lack of time; it is the main reason to promote the acquisition of this gesture. The participants also indicate among other obstacles the feeling of not meeting the expectations of the scholar institution. Indeed, it appears that the institution requires bringing learners to a practice level 2 according to the codification of the French Federation of Volleyball for beginners, without being able to provide the hours necessary to achieve this. Consequently, the teachers do not take the time to set up learning tasks that would be more favorable to the acquisition of gesture by the learners, nor to produce feedback that would further develop the skills, but prefer to go quickly to complete the programs. The result is that learners are not exposed to sufficient amount of input and do not perform activities that would allow the in-depth processing of this input which further hinders acquisition. In addition, management time becomes more complicated when it is crossed with the management of pupil behavior. Discipline is a central element in the discourse of the teachers observed and seems to partly explain their choices. We can therefore see the importance of taking a step back from the representations that we construct about teachers in the face of their involvement in order to be able to set up practices consistent with the Trinquier's theory. With regard to the other difficulties encountered by the pupils, the return of the ball was cited by the teachers. This obstacle is also underlined by Osborne et al. (2016). According to these authors, students often hit the ball on the left or right parts of the landing plate because of its poor formation (presentation of the outer sides of the forearms instead of the inner parts). This learning is fundamental and constitutes a major achievement for the practice of volleyball at a high level (Degrenne, 2019; Langlois, 2018) and takes a lot of time (2 to 3 lessons depending on the size of the class). To remedy this, it would then be advisable to increase the number of groups within the class and also the number of balloons. In the context of poor sports equipment in schools in the Congo, only a significant contribution from the state can substantially improve the conditions for learning this volleyball cuff gesture.

Finally, from the analysis of corpus of our interviews, it emerges that the representations on the cuff volleyball among the physical education teacher impact pedagogical relations and reinforce the construction of differences between the sexes. Indeed, as Guichard-Claudic and Kergoat (2007: 3) note, "it is on the body that we base the

idea of skills specific to each sex". In addition, since authority is perceived according to some representations as a male competence, it is associated with bodily characteristics also represented as male, an observation which remains consistent with those resulting from other studies (Ananga, 2021; Nuria et al., 2018). The gendered body thus appears, through our results, as a social element to be carefully staged (Butler, 2005; Verscheure et al., 2006). In short, the results of the representations of our teachers suggest that social relations of sex are perceived as having to be thwarted, overcome or deconstructed in order to found "professional competence" (Prairat, 2012). This is a set of pedagogical strategies deployed by physical education teachers to "manage impressions" (Goffman, 1996) and their own representations of the skills involved in cuff teaching. These strategies involve establishing institutional order by negotiating the success of this power, or "statutory authority" endowed by the educational institution (Mayeko and Brière-Guenoun, 2019). In addition to strategies for neutralizing the gendered body, some teachers in our study accentuate the skills gap in age in order to consolidate their non-dominant position, by playing on this other system of unequal social relations (Bessin and Blidon, 2011). Others prefer attitudes or behaviors that compensate for gendered representations. They express that they are not "afraid" of the mistrust placed on them as regards to the supposed physical strength of their male counterparts by "asserting themselves immediately" in order to prevent gendered representations from continuing. All of these strategies aim to bring together the conditions allowing them to move towards educational authority by taking into account their representations towards the volleyball, particularly the cuff technique.

However, certain precautions should be taken into account when interpreting the results presented. The type of questionnaire constructed to identify teachers' representations was based on a hybrid questionnaire. If according to Abric (1997), this tool has the advantage of borrowing other methods in the context of work on social representations, Nachmias and Nachmias (1996) (1996) maintains that the open questions used present a certain number of drawbacks, linked in particular to the fact that the information collected may be too dispersed. In addition, the use of open-ended questions teaches that many answers can be fuzzy, incodable. However, the free association method advocated by Abric constitutes a compromise about the choice of open / closed questions, through the "open-ended" questions that we used in this survey. In addition, a second weakness of the study is the small number of subjects ( $n = 86$ ); this does not authorize the generalization of the conclusions obtained to the entire population of physical education teachers in the Congo. The third limitation is that participation in the study was strictly voluntary. Again, there is a good chance that the teachers must be motivated by their practice

participated, to the detriment of the less enthusiastic teachers, and therefore the most likely not to teach the headline during the volleyball lessons. These limitations do not, however, completely affect the power of the observations. However, this study has the merit of having addressed the evaluation of the representations of physical education teachers in black Africa regarding the teaching of volleyball cuff. In addition, our experimental work followed protocols similar to other previous studies on representations (Al-Tawel and Al-Ja'afreh, 2017; Castejon and Giménez, 2015).

## Conclusion

The study concludes that in volleyball cuff's teaching during physical education lessons, teachers' knowledge of representations is essential. Our results highlight seven main reasons and obstacles for teachers: lack of time, lack of material, lack of space, excessive numbers, perception of pupils, seniority in the teaching profession, and level of initial training. Even if some teachers have a significant personal connection to the knowledge to be taught, the majority of them present themselves as teachers working in a relatively difficult ecological and educational context. Their representations highlight pedagogical misunderstandings, that is to say differences in representation. They participate in socio-professional, motivational, ecological and didactic variables, by acting on practices. By reinforcing, neutralizing, colliding, or not meeting, they hinder or on the contrary help the process of teaching this technical gesture.

## CONFLICT OF INTERESTS

The authors have not declared any conflict of interest.

## REFERENCES

- Abric JC (1997). *Pratique sociale et représentation*. Paris: Editions PUF.
- Al-Tawel AM, AlJa'afreh IA (2017). Competencies in Physical Education Teaching: An Investigation of Teachers' Perceptions in the Southern Governorates of Jordan. *Journal of Studies in Education* 7(2). doi:10.5296/jse.v7i2.11262.
- Amans-Passaga C, Verscheure I. (2020). Construire des pouvoirs moteurs en volley-ball en EPS: étude didactique au cycle 3 de l'école primaire. *Staps*. 4(130):79-96.
- Ananga E. (2021). Gender Responsive Pedagogy for Teaching and Learning: The Practice in Ghana's Initial Teacher Education Programme. *Creative Education* 12:848-864.
- Atoun Carlos EH, Agbodjogbe B, Attiklemé K, Sedode G, Kpazaï G (2018a). L'influence de l'épistémologie sur la pratique enseignante du volleyball au Bénin. *IOSR Journal of Sports and Physical Education* 5(5):27-40.
- Atoun CEH, Agbodjogbe B, Attiklemé K, Kpazaï G, Ahodonou C (2018b). L'enseignement de l'attaque au volleyball en classe de terminale: cas des collèges du zou en république du Bénin. *IOSR Journal of Research and Method in Education* 8(5):18-27.
- Attiklemé A, Kpazaï G (2011). Analyse de l'évolution des curriculums de l'enseignement de l'Éducation Physique et Sportive (ÉPS) en République du Bénin de la période coloniale à nos jours. *La Recherche en Éducation* 6 83-99.
- Attiklemé K (2009). L'analyse comparée des savoirs enseignés en natation dans les classes de 6ème des collèges et lycées du Bénin et de la France. Rapport de Recherches entre le Laboratoire des Sciences de l'Homme et de la Société de l'INJEPS/UAC (Bénin) et le DiDiST-CREF-T de l'Université de Toulouse (France), pp 41-67.
- Backman E, Barker DM (2020). Re-thinking pedagogical content knowledge for physical education teachers – implications for physical education teacher education. *Physical Education and Sport Pedagogy* 25(5):451-463.
- Bandura A (1990). *L'apprentissage social*. Paris: Mardaga.
- Bessin M, Blidon M (2011). Dossier « Vieillir ». *Genre, Sexualité et Société*, 6.
- Bourdieu P (1980). *Le sens pratique*. Paris: Minuit.
- Bourdieu P (2006). *Le capital social*. Notes provisoires. In: Bevort A, Lallement M (dir.), *Le capital social. Performance, équité et réciprocité*. Paris: Editions La Découverte, Collection Recherches/MAUSS pp. 29-34.
- Butler J (2005). *Trouble dans le genre. Pour un féminisme de la subversion* (traduit par Cynthia Kraus). Paris: Editions La Découverte.
- Castejón FJ, Giménez FJ (2015). Teachers' perceptions of physical education content and influences on gender differences. *Motriz Rio Claro* 21(4):375-385.
- CNSEE (2021). *La République du Congo en chiffres, 2018. Rapport du recensement de la population, de l'habitat, des petites et moyennes entreprises et de la qualité de vie*. Brazzaville: Centre National de la Statistique et des Etudes Economiques.
- Connell JP, Wellborn JG (1994). Competence, autonomy and relatedness: a motivational analysis of self-system processes. In: Gunnar Jr, Srouffe LA (eds) *Self-processes in development. Minnesota symposium on child psychology*. Hillsdale, NJ: Erlbaum 23:43-77.
- Crocker L, Algina J (1986). *Introduction to classical and modern test theory*. Holt, Rinehart and Winston, 6277 Sea Harbor Drive, Orlando, FL 32887, 1986.
- De Ketele JM (1985). *Docimologie, introduction aux concepts et aux pratiques*. Louvain la Neuve: Editions Cabay.
- Degrenne O (2019). *Caractérisation des évolutions de jeu en volley-ball de haut-niveau: Étude comparative de trois compétitions internationales*. Thèse de doctorat Université Paris-Est Créteil, Créteil France.
- Délicieux D, Garsault C (1991). Pertinence scientifique et légitimité idéologique: le recours aux modèles psychologiques en Education Physique et Sportive. In: Collinet C (dir.) *EPS et sciences*. Paris: PUF, pp.25-42.
- Eloi S (2000). Représentations mentales et acquisition d'habiletés tactiques en volleyball: effets comparés de deux cycles d'enseignement. *Sciences et motricité* 40:22-31.
- Ferry M (2018). Physical education preservice teachers' perceptions of the subject and profession: development during 2005-2016. *Physical Education and Sport Pedagogy* 23(4):358-370.
- Gil-Arias A, Diloy-Peña S, Sevil-Serrano J, García-González L, Abós Á. (2021). A Hybrid TGfU/SE Volleyball Teaching Unit for Enhancing Motivation in Physical Education: A Mixed-Method Approach. *International Journal of Environment and Research in Public Health* 18:110.
- Goffman E (1996). *La mise en scène de la vie quotidienne*. Paris: Éditions de Minuit.
- Gréhaigne JF (1992). *L'organisation du jeu en football*. Paris: Actio.
- Gréhaigne JF, Billard M, Laroche JY (1999). *L'enseignement des sports collectifs à l'école. Conception, construction et évaluation*. Bruxelles: Editions De Boeck Université.
- Guichard-Claudic Y, Kergoat D (2007). Le corps aux prises avec l'avancée en mixité. *Cahiers du Genre* 1(42):5-18.
- Haye G (2012). *Le plaisir*. Paris: Editions Revue EPS, collection Pour l'action.
- INRAP (2005). *Le programme d'enseignement de l'éducation physique et sportive du secondaire (2ème degré)*. Brazzaville: Ministère de l'enseignement primaire et secondaire.
- Langlois V (2018). L'analyse du rapport d'opposition en volleyball: modélisation et création d'un outil d'évaluation de la norme du jeu

- lors des Jeux Olympiques de Rio en 2016. Thèse de doctorat Université Paris-Est Créteil, Créteil France.
- Lepuissant S (2016). Le volley-ball : un sport « très technique » ? In: Gréhaigne J-F, Les objets de la technique. Repenser la technique dans ses relations aux stratégies collectives de jeu. Rennes : Presses Universitaires de Franche-Comté pp. 183-209.
- Milos T, Bojan L, Marjeta K (2019). The professional competences of physical education teachers from north-eastern Italy. CEPS Journal. 9 (1 Suppl.): 103-120.
- Moldoveanu M, Grenier N, Steichen C (2016). La différenciation pédagogique: représentations et pratiques rapportées d'enseignantes du primaire. *Mc Gill Journal of Education* 51(2):745-768.
- Moliner P, Rateau P, Cohen-Scall V (2007). Les représentations sociales, Pratique des études de terrain. Rennes: Presses Universitaires de Rennes.
- Mviri C (2018). Problématique de l'enseignement de l'éducation physique et sportive dans les établissements secondaires et supérieure de Brazzaville: Formation, Planification et Absentéisme, Doctoral dissertation thèses in educational sciences, Unesco chair, Brazzaville (Congo), Marien Nguabi University.
- Nachmias D, Nachmias C (1996). Research methods in social sciences, 5th edition. New York: St Martin's Press.
- Nuria S, Daniel M, Susanna S, Anne F (2018). Challenging gender relations in PE through cooperative learning and critical reflection. *Sport Education and Society* 23(8):1-12.
- Oguéboulé B (1999). L'enseignement de l'éducation physique et sportive dans les lycées et collèges du Bénin : la place des sports collectifs. Master thesis STAPS, INJEPS-, Porto-Novu, Université Nationale du Benin.
- OI (1970). Circulaire No00069/HCS-DS-4 du 13 janvier 1970, portant les instructions officielles à l'usage des Professeurs, Maîtres et Moniteurs d'Education Physique et Sportive.
- Osborne R, Saraiva Belmont R, Portal Peixoto R, Santos de Azevedo IO, Paiva de Carvalho Junior AF (2016). Obstacles for physical education teachers in public schools: an unsustainable situation. *Motriz Rio Claro* 22(4):310-318.
- Perrenoud P (1995). Des savoirs aux compétences : de quoi parle-t-on en parlant des compétences ? *Pédagogie Collégiale* 9(1):20-24.
- Poussin B, Dénervaud H, Lenzen B (2014). La contribution de l'éducation physique au développement de la démarche réflexive des élèves: quelles techniques didactiques mises en œuvre par les enseignants lors d'un cycle de volley-ball ? *eJournal de la Recherche sur l'Intervention en Education Physique et Sport* <https://doi.org/10.4000/ejrieps.2269>
- Magendie É, Bouthier D (2013). L'expérience d'élèves en difficulté en éducation physique et sportive : analyse d'une activité mise en souffrance. *Revue des sciences de l'éducation* 39(2):315-339.
- Mayeko T, Brière-Guenoun F (2019). Les gestes de différenciation en éducation physique et sportive : le cas d'un enseignant débutant exerçant en milieu difficile. *Activités* 16:2.
- Prairat E (2012). L'autorité éducative au risque de la modernité. *Recherche et Formation* 3(71):13-28.
- Quennerstedt M (2019). Physical education and the art of teaching: transformative learning and teaching in physical education and sports pedagogy. *Sport, Education and Society* 24(6):611-623.
- Romar J-E, Ferry M (2019). The Influence of a Methods Course in Physical Education on Preservice Classroom Teachers' Acquisition of Practical Knowledge. *Journal of Teaching in Physical Education* 39(3):374-383.
- Rosenthal R, Jacobson L (1969). Pygmalion in the classroom. Teacher expectation and pupils intellectual development. *Revue Française de Pédagogie* 7:70-72.
- Scrabis-Fletcher K, Silverman S (2017). Student Perception of Competence and Attitude in Middle School Physical Education. *The Physical Educator* 74(1):85-103.
- Silva BVF, Henrique dos Santos R, Rocha Savarezzi G, Teodoro de Souza M, Gimenez R (2020). Teaching strategies in physical education: a confrontation between directive and indirect styles in volleyball learning. *Journal of Physical Education* 31:e3168.
- Sood Al-Oun I, Shaddad Qutaishat R (2015). Physical Education Teacher Attitudes towards the Effectiveness of Sport activities in Northern-East Badia. *Journal of Education and Practice* 6(13). [www.iiste.org](http://www.iiste.org).
- Terrisse A (2001). Didactique des disciplines: Les références au savoir. Bruxelles: Editions De Boeck Université.
- Therriault G, Bader B, Lapointe C (2011). Redoublement et réussite scolaire : une analyse du rapport au Savoir. *Revue des Sciences de l'Éducation* 37(1):7-211.
- Trinquier M-P (2001). Représentations de la petite enfance et de son rapport au savoir dans les salles d'asile et en école maternelle. In: Penser l'éducation, no8, Rapport de Recherches, Laboratoire CIVIIC, Université de Rouen.
- Trinquier M-P (2011). Enseignement, représentations et pratiques. Confronter le sociocognitif au pragmatique : continuités et ruptures d'une relation. Thèse d'Habilitation à Diriger des Recherches en sciences de l'éducation, Toulouse (France), Université Toulouse Le Mirail (Toulouse II).
- Verscheure I, Amade-Escot C, Chiocca C-M (2006). Représentations du volley-ball scolaire et genre des élèves: pertinence de l'inventaire des rôles de sexe de Bem ? *Recherches en Éducation*. 154:125-144.

*Review*

# Scholars and educational positions under criticism and praise in the Medieval Islamic Era

Hatim Muhammad Mahamid\* and Younis Fareed Abu Al-Haija

Department of Education, Faculty of Management and Organization of Education Systems, Sakhnin College for Teachers' Education, Isreal.

Received 14 June 2021, Accepted 28 July 2021

**This research focuses on criticism and praise in Arabic literature, history and poetry towards those in charge of the scientific movement in the Medieval Era. The research method was theoretical and qualitative. Many poets and scholars praised the rulers and sultans who established mosques and other educational institutions (madrasa-s) based on endowments, which had a role in sciences, intellectual and religious renaissance. They were subject to criticism or praise for their work or the educational role they followed. The topics of praise to the ulama centered on, their diligence and dissemination of science, as well as of their behavior and moral manners. On the other hand, the criticism of poetry centered on the mistakes of some scholars, their scientific stances in religious matters and criticizing scholars of the sultans for their attitudes in serving the rulers. Poets were also interested in criticizing scholars (ulama) who moved away from the path of morality, virtue, and shari'a, and who lead the teaching without qualification or mismanagement of the educational process; and therefore do not preserve the rules of morality in lessons, education or discussions, and their lack of good morals towards students.**

**Key words:** Arabic literature, criticism and praise, science and scholars, rulers and sultans, Medieval Era.

## INTRODUCTION

Scholars (ulama) had the main position in the educational and religious life in medieval Islamic history. Students' sessions were organized according to topics and specialties, besides they were known by scholars' names or by their educational topic. So, students were not affiliated to the educational institutions but rather to their scholars, known by their fame. In consequence, scholars were considered the first reference in the educational activities of the medieval ages. After the spread of madrasas and other educational institutions which

became reliant on funding from endowments of rulers, Sultans and wealthy benefactors, scholars were connected with the endowments and their owners. So, it was usual to see that scholars were divided between the loyalists of the authority (Scholars of the Sultans) and being independent scholars in work and opinions. Thus, scholars had increased their strength and leadership position not only in their performance as teachers, but also in the management and educational activities of madrasas.

\*Corresponding author. E-mail: [hatim\\_mahamid@hotmail.com](mailto:hatim_mahamid@hotmail.com).

Unfortunately, with the political, economic and social changes and developments, corruption started to spread in the educational institutions, especially in the late Mamluk era (since the late fourteenth century) in Egypt and the Levant.

Both rulers and scholars needed to support and help each other; the rulers needed to legitimize their authority with the support of scholars, while scholars were competing for religious, educational and administrative posts under the rulers.

This was one of the most important and notable factor that led to the extent of corruption phenomenon and to taking over the endowments-funds for personal interests, which was known by several labels in that period, such as: "*al-badhī*", "*al-barṭīl*, *al-sa'ī*" (bribery) and the pursuit of rulers and sultans to obtain important posts in *madrāsas* and other educational and religious institutions, and even in judicial posts as well. Anyone who wanted a post in *madrāsa* or the judiciary, paid money depending on the importance and status of the posts (Ahmad, 1979; Mahamid, 2013: 113-129).

As a result, the scholars of authority (*'ulama' al-sulta*) and those close to them dominated the scientific movement in schools and *waqf* institutions, and those scholars were exposed to criticism by other scholars, such as Sheikh 'Izz al-Din ibn 'Abd al-Salam (d. 660 AH/1262 AD) and Ibn Taymiya (d. 728 AH/1328 AD), who were not close to rulers and wielded no political influence. Scholars, writers and poets also wrote a lot to describe the educational activities at this point, either praising or criticizing to reform things, or as a way to deter the corrupt people in this field, by criticizing or mocking them and exposing their actions contrary to religion and law. The majority of scholars were proficient in poetry and Arabic language with its branches, in addition to their involvement in religious subjects. Thus, this research mainly focuses on the subject of criticism and praise, the aspects associated with the educational activities, such as scholars, endowments and even contributors for constructing religious and scientific institutions.

## **OWNERS OF MADRASAS AND RELIGIOUS INSTITUTIONS BETWEEN CRITICISM AND PRAISE**

Many poets and scholars praised the rulers who contributed in establishing *madrāsas* and specified endowments for funding and maintaining them. In their historical writings, Muslim historians described these educational and religious institutions, their importance, impact on the spread of religious sciences, the fight against "*bid'a*" and all that contravene the instructions of the Qur'an and the Sunna. So, the laudation and praise for those contributors of charity appeared in poetry, prose, and their biographies. For example, 'Imad al-Din al-Isfahani was a teacher in Damascus and an advisor to Sultan Nur al-Din Maḥmūd bin Zengi (d. 569 AH/1174

AD), and then to Sultan Salah al-Din al-Ayyubi (d. 589 AH/1193 AD). Isfahani praised Sultan Maḥmūd bin Zengi and Salah al-Din al-Ayyubi for their policy that benefited the Islamic religion, building schools in order to spread religion and revive the Sunna, and fighting "*bid'a*" and "*Shi'a*" in Syria and Egypt (al-Maqdisi, 1991, 1:288).

When Sultan Najm al-Din Ayyub (d. 647 AH/1249 AD) ruled Egypt and Syria in the late Ayyubid era, he built a school in Cairo known as "*al-Salihiyya*", and arranged lessons for jurists of the four doctrines in 641 AH/1243 AD. Al-Siraj al-warraq praised and bragged of its status as the superiority of "*al-Nizamiyya*" *madrāsa* in Baghdad (Ibn Iyas, 1983, 1/1: 272-273; Al-Suyuti, 1968, 2:263). In the Mamluk era, building *madrāsas* and their endowments were increasing and the educational movement that established on Sunni doctrinal grounds spread out, as well as competition in this field increased. Shams al-Din ibn al-Sayigh praised the Mamluk Amir Sarghatmush when he established a *madrāsa* in Cairo in 757 AH/1356 AD, for its status and importance (Ibn Iyas, 1983, 1/1:555; al-Suyuti, 1968, 2:268; al-Maqrizi, 1997, 4:228).

Moreover, al-Shihab ibn abi Hijla praised the Mamluk leader Shikhu for building the Sufi "*khanqah*" and a mosque in Cairo in 757 AH/1356 AD, and Shikhu was one of the most dignified princes and actually the most well-known for his good deeds and love for scholars, righteous and Sufis. He contributed in many abundant endowments for knowledge sessions and scholars of the four doctrines (Ibn Iyas, 1983, 1/1:557-558; al-Suyuti, 1968, 2:266; al-Maqrizi, 1997, 4:220). In addition, Sultan Hasan (d. 762 AH/1361 AD) was praised and congratulated by the writer Ibn Nubata, when he built his *madrāsa* in Cairo to serve the four Sunni doctrines with its mosque, and he became one of the masterpieces of what were built in the Mamluk state (Ibn Iyas, 1983, 1/1:559-561). The Egyptian writer Ahmad Ibn al-'Attar also praised the Mamluk Sultan al-Zahir Barquq (d. 801 AH/1399 AD) when he finished building his *madrāsa* "*al-Zahiriyya*" and its facilities in 788 AH/1386 AD, which included several institutions and architectural building in Cairo, including the *madrāsa* itself, the mosque, the *khanqah* and the dome (al-Suyuti, 1968, 2:271; Ibn Iyas, 1983, 1/2:351-373).

On the other hand, some contributors in such institutions faced some kind of criticism for what had been shown as corruption or dysfunction in their charitable work. For example, the Mamluk Sultan Al-Mu'ayyad Shikh (d. 824 AH/1421 AD) was exposed to criticism and ridicule for his controlling of some buildings and facilities in Cairo in order to build his mosque in 818 AH/1415 AD, including the doors of Sultan Hasan's *madrāsa* and others. Later on, one of the mosque's minarets fell down, which make people mocking him for his approach in obtaining funds for building the mosque illegally (Ibn Iyas, 1983, 2:20-21, 31, 35-36; Ibn Taghri Birdi, 1970, 14:43-44, 75-76; Ibn al-'Imad, 9, 1992: 212; Al-Suyuti, 1968, 2:272-273).

## SCHOLARS BETWEEN PRAISE AND CRITICISM

Scholars (*ulama*) formed the link between the common people on one hand, and the upper class of rulers, Sultans and other people of power on the other. Some scholars who were heads of religious posts in the *ifta'*, the judiciary, teaching and preaching, and some also had administrative and *hisba* (market) posts. Therefore, *ulama* were the focus of everyone's attention, for their manners, habits, knowledge and performance in these public and private posts. It is natural that they were exposed to either criticism and censorship or praise by everyone. After the increase of scholars of Islamic doctrines for reviving the Sunna and the religious sciences because of intellectual and doctrinal conflicts up until the end of the first Abbasid era, rivalries between the Sunnis themselves remained with the emergence of Sufi movements, and conflicts over posts with the spread of the *madrasa*, religious and educational institutions and endowments. A lot of examples of those scholars and their criticism or praise can be shown, especially in the late medieval ages.

For example, Abu Hamid al-Ghazali (d. 505 AH/1111 AD) reached a high status in religious sciences and education, but this did not prevent him from being exposed to many different situations from scholars between supporters and opponents, and between criticism and praise for his ideas and religious views. Actually, al-Ghazali was criticized for his rational views of the *Ash'ariyya* thought, asceticism and Sufism. On the other hand, he was praised for some of his religious writings, such as his book "*Ihya' Ulum al-Din*". Also, he wrote many books attacking philosophers and Shi'ites such as: "*Maqasid al-falasifa*" and "*Ijām al-'Awām 'an 'Ilm al-Kalām*". In his book "*Tahāfut al-Falāsifah*", he refuted the Greek Philosophy and their ideas, and he attacked Shi'ites and their ideas and beliefs in the book of "*Fada'ih al-Batiniyya*" (Al-Ghazali, 2020: 16-30).

Sheikh al-'Izz Ibn 'Abd al-Salam (d. 660 AH/1262 AD) was one of the greatest scholars called as *Sheikh al-Islam* and *Sultan al-'Ulama*. Many historians had praised him by writing his biography, such as Ibn Iyas for example, which says: "he is famous in teaching knowledge, promotion of virtue, prevention of vice and he is harsh with Sultans and rulers. He actually learnt from Sheikh Fakhr al-Din Ibn 'Asaker, he had miraculous dignity and he learnt to be Sufi from Shahab al-Din al-Suhrawardi..." (Ibn Iyas, 1983, 1/1:317-318; Ibn Qadi Shuhba, 1979, 2:137-140; al-Isnawi, 1987, 2:84-85; al-Maqdisi, 2002: 330; Ibn Taghri Birdi, 1999, 7; Al-Dhahabi, 1999). Also, Sheikh Muhyi al-Din al-Nawawi (676 AH/1277 AD) was one of the most famous of the Shafi'i *ulama* in Damascus, he died at the age of forty-five years, and had reached a high status in his religious life and sciences. He was one of the diligent and leading imams; some scholars praised him for his diligence in the judiciary, *fiqh*, teaching and writing books (Ibn Iyas, 1983, 1/1:364; Ibn Qadi Shuhba, 1979, 2:194-200; Al-Isnawi,

1987). Sheikh Zayn al-Din Ibn al-Wardi mentioned the descriptions and titles of al-Nawawi, which referred to his status saying: "*Sheikh al-Islam, al-'alim, al-zahid, al-rabbani*, he had an exclusive biography about his personal sciences, writings, belief, certainty, piety, asceticism and conviction" (Ibn al-Wardi, 1996, 2:219).

Sheikh Taqiy al-Din Ibn Daqiq al-'Id (d. 702 AH/1302 AD) was a prominent scholar in his time, and his death in Egypt was heartbreaking for scholars, as he was described by al-Subki: "Sheikh al-Islam who is *al-hāfiz, al-zahid, al-wari', al-nnasik, al-mujtahid and al-muṭlaq*, he was fully experienced in religious sciences, he also combined between science and religion..." (al-Subki, 1968, 9:207-249; al-Isnawi, I, 1987: 317-320; al-Isnawi, 2, 1987: 102-106; Ibn al-Wardi, 1996, 2:244; al-Shukani, 2, 1998: 229-232; Ibn Iyas, 1983, 1/1:411-412; Ibn Qadi Shuhba, 1979, 2:299-302). He was praised by Al-Suyuti, the Tunisian Imam al-Maliki Ibn al-qawba' and Sheikh Sharaf al-Din Muhammad al-Qusi for his high degree in diligence, his reaching to the top level of science in his time, his writings, moral advantages and religious and scientific status (al-Suyuti, 1968, 1:317-320; al-Isnawi, 1987, 2:103; al-Subki, 1968, 9:210).

As for the scholar Taqiy al-Din Ibn Taymiya (d. 728 AH/1328 AD), a lot of controversy was raised around him in his life as well as after his death, between supporters and opponents for his dealing in some situations and for some of his *fatwas*, which are due to his tough and controversial views among many scholars (Ibn Hajar al-'Asqalani, 1993, 1:144-160; Al-Nu'aymi, 1988, 1: 32, = 33, 211, 2:214-215; Al-Shukani, 1998, 1:64-65). Despite that, when he died, his funeral was massive, and it was estimated by two hundred thousand funeral-goers, that showed his distinguished status in his time. Besides, he was given an elegy and praised by groups of scholars and writers, including Ibn al-Wardi, al-Shukani, al-Dhahabi and others, who described him to be distinguished and that he had high scientific ability and status (Ibn al-Wardi, 1996, 2:275-279; Al-Nu'aymi, 1988, 1:75-77; Ibn al-'Imad, 1992, 8:142-150; Ibn Taghri Birdi, 9, 1970: 271-272; Ibn Kathir, 14, 1988: 135-140; Al-Shukani, 1998, 1:63-72). Ibn Taymiya was also praised by the historian and scholar Ibn Kathir, who had a good relationship with him since childhood. Ibn Kathir respected, appreciated, praised him in his biography, and also cited praise for him from the poetry of Sheikh Ibn al-Zamalkani (Ibn Kathir, 1988, 14:137, 139; Ibn al-Wardi, 1996, 2:278).

The Andalusian Imam and scholar Athir al-Din Muhammad al-Ghirnaṭi (d. 745 AH/1344 AD) was well known for his stay in Egypt, where he learnt from senior scholars until he surpassed them in his time. He was proficient in science, grammar and poetry, and he wrote venerable books. Besides, he was a great poet as usual for the emigrated Andalusian scholars to the Levant. He received much praise and elegy after his death for his scientific and literary status from many historians and scholars, such as Salah al-Din al-Ṣafadi, Ibn Iyas and

others (Ibn Iyas, 1983, 1/1:501-502). The historian Shams al-Din Muhammad Ibn 'Abd-Allah al-Dhahabi (d. 748 AH/1348 AD) was considered as critic by many previous scholars, where he actually was not fair in their biographies, and he mentioned this in his writing whether it was praise or criticism, for their scientific and religious positions. Taj al-Din al-Subki mentioned in his biography of al-Dhahabi that he was the top of *hadith*'s scholars and one of the four protectors of *hadith* in that era. Al-Subki said in his book "*Tabaqat al-Shafi'iyya*" that al-Dhahabi has no counterpart, and he was the gold of the era literally and actually, as if the nation was gathered and he saw it, then began to write about it (al-Subki, 9, 1968: 101). Al-Dhahabi learnt *hadith* at a young age from senior scholars of *hadith* in several places in the Syria, Egypt and Mecca. He also left a rich legacy of historical writings and classifications, biographies, *hadith* and other sciences; the most notable of his book was "The History of Islam". When he died, al-Dhahabi received praise and eulogy from many of his students such as Taj al-Din al-Subki and others (al-Subki, 1968, 9:100-123; Ibn Kathir, 1988, 14:225; Ibn Hajar al-'Asqalani, 3, 1993: 336-338; Al-Nu'aymi, 1, 1988: 78-79; Ibn al-'Imad, 1992, 8:264-268; al-Isnawi, 1987, 1:273-274; Ibn Taghri Birdi, 10, 1970: 182-183).

As for the Shafi'i scholar Taj al-Din al-Subki (d. 756 AH/1355 AD), he was a descendant of senior scholars who had many religious posts in judiciary and teaching in Egypt and the Levant. When he died, he received praise, honor, and eulogy from the writer Sheikh Jamal al-Din Ibn Nubata (Ibn Iyas, 1983, 1/1:556-557). Also the famous historian and scientist Salah al-Din bin Aybak al-Safadi (d. 764 AH/ 1363 AD), received praise and eulogy from many scholars when he died, such as Ibn Nubata al-Masri who mentioned al-Safadi's knowledge, virtues and writings, including the historical books "*al-Wafi bil-Wafaya*", "*A'yan al-'Asr wa-A'wan al-Nasr*" and other writings (Ibn Iyas, 1983, 1/2:7; Ibn Qadi Shuhba, 1979, 3:119-121).

The family of Ibn Jama'a was famous for its high status in religious matters and posts in the judiciary and teaching in the Levant and Egypt, among them are 'Izz al-Din 'Abd al-'Aziz Ibn Badr al-Din Ibn Jama'a (d. 767 AH/1366 AD) (Salibi, 1958:97-109). He was a religious scholar, strict in Shari'a matters, virtuous from bribery and took nothing from Sultans and rulers; he even left his post in the judiciary to avoid suspicions of bribes. Some writers praised him for his posts and lack of closeness to the rulers. 'Izz al-Din Ibn Jama'a was a virtuous scholar, and he taught *hadith*, *fiqh*, *ifta'*, speechify and took over the judiciary in Egypt. He followed the approach of his father, Badr al-Din Ibn Jama'a (Ibn Iyas, 1983, 1/2:32; Al-Suyuti, 1968, 1:359; Ibn al-'Imad, 1992, 8:358-359; Al-Shukani, 1998, 1:359-360; Ibn Qadi Shuhba, 1979, 3:135-138).

Additionally, the descendants of Ibn Jama'a were distinguished by chastity and virtues, who emerged from

Burhan al-Din Ibrahim Ibn Jama'a (790 AH/1388 AD). He voluntarily removed himself from the post of the judiciary several times to get away from authority, and then he returned after the Sultan appeased him. He had religious and educational posts in Jerusalem, Egypt and Damascus, ended up to be the leader of scholars and he was well-loved by people. He was a good public speaker, teacher, judge, and then became sheikh al-sheikhs of Sufism in Damascus, as mentioned by Mujir al-Din al-'Ulaymi al-Hanbali (Al-'Ulaymi, 2, 1999: 186-187; Ibn Hajar al-'Asqalani, 1, 1993: 38-39; Ibn Iyas, 1983, 1/2:142; Al-Suyuti, 1968, 2:161; Ibn Taghri Birdi, 1970, 11:314-315; Ibn Qadi Shuhba, 1979, 3:188-190; Ibn al-'Imad, 1992, 8:533-534; Salibi, 1958).

The nicknames mentioned by historians about the description of some scholars were a sign of their status, elevation for their posts, respect for them as an expression of praise and thanks for their status, and a tribute by poets, writers and historians. Ibn Iyas described the scholar Akmal al-Din Muhammad al-Babarti al-Rumi al-Hanafi in his biography (d. 786 AH/1384 AD), for example, he praised him for his virtue and advantages in science and his high status, where they offered him posts of the judiciary and he refused them. Ibn Iyas referred to him by several names, such as "unique of his time, *shaykh al-shuyukh*, he was an Imam, a virtuous scholar, proficient in science, a good ascetic, a religious scholar, refusing to get senior posts " (Ibn Iyas, 1983, 1/2:351-353; Al-suyuti, 1968, 1:471). Abu Hafis Siraj al-Din 'Umar Ibn Raslan al-'Asqalani al-Shafi'i (d. 805 AH/1402 AD) received similar descriptions and nicknames such as: *ri'asat al-'ilm*, *baḥr al-'ulum*, *farid 'asrihi wa-wahid dahrihi*. The scholar Ibn Hajar al-'Asqalani recited a lengthy poem highlighting his religious, scientific, and moral ethics (Al-Suyuti, 1968, 1:329-335; Ibn Iyas, 1983, 1/2:674-675; Al-Sakhawi, 1992, 6:85-90).

As for Zayn al-Din 'Abd al-Rahim al-'Iraqi (d. 806 AH/1403 AD), when he died, he received praise and eulogy from his pupil Ibn Hajar al-'Asqalani in a poem to honor him and maximize his scientific and educational status. Al-'Iraqi had been described by historians and people of his time with several qualities that indicated his status in the science of *hadith*, classification and preservation (Ibn Iyas, 1983, 1/2:692; Al-Suyuti, 1968, 1:360-362). Besides, when Shihab al-Din Ahmad Ibn Hajar al-'Asqalani (d. 852 AH/1449 AD) died, he received praise and eulogy, where great sadness prevailed among his peers from scholars, writers and poets. Ibn Hajar al-'Asqalani was knowledgeable in many fields of literature, poetry and religious sciences, and excelled in *hadith*'s sciences. He wrote many books, including: "*Sharḥ al-Bukhari*", "*al-Iṣaba fi Tamyiz al-Ṣahaba*", "*al-Durar al-Kāmina*" and others. Historians and biographic, including Ibn Taghri Birdi, Ibn Iyas and others, had concurred in the descriptions and nicknames of Ibn Hajar al-'Asqalani, which he obtained through his numerous posts and scientific and religious status (Ibn Taghri Birdi, 15, 1970:



532-534; Ibn Iyas, 2, 1983: 268-271; Al-Suyuti, 1968, 1:363-364; Al-Sakhawi, 1992, 2:36-40; Ibn al-'Imad, 9, 1992: 395-399; Al-Shukani, 1998, 1:87-92).

### CRITICISM OF SCHOLARS ABOUT THEIR CLOSENESS TO RULERS AND AUTHORITY

There were some scholars who came close to rulers in order to get religious and scientific posts, which made them subject to criticism by many other scholars who saw them as "Scholars of Sultans" (*'ulama' al-salatin*). For example, Ibn 'Abd al-Birr mentioned many *hadiths*, narrations and poems about scholars' getting close and coming to Sultans and rulers, for example the Hadith: "two types from my nation if they be good, then all people will be good: princes and jurists", and also from the sayings: "the worst princes are the farthest from scholars and the worst scholars are the closer to the princes" (Ibn 'Abd al-Birr, 2008, 1:331-354; Ibn 'Abd al-Birr, 1994, 1:631-647).

In addition, many scholars had written about getting away from authority because of its negative effects and faring away from *shari'a*. For example, al-Suyuti classified a book in this field, titled: "*ma rawahu al-asaṭin fi 'adam al-maji' ila al-'umara' wal-salatin*" (what the legends narrated badly about coming to the princes and sultans), in which he listed many prophetic *hadiths* and relics about good predecessor in this field of entering into the palaces of princes and sultans, because that might make scholars to be silent about the vices and impoliteness of the rulers, besides trying to satisfy those rulers over the right of *shari'a* matters and manners. He also warned about the phenomenon of coming close to princes and sultans (Al-Suyuti, 1991:67-70).

In the second era of the Mamluk state, corruption spread due to the political, military and economic conditions, so the phenomenon of "scholars of authority" began to increase among rulers and sultans, some of manifestations of corruption were: bribery, taking over the endowments and funds and increasing in their collection arbitrarily by judges and princes, who used their posts in the administration of State Affairs, judiciary, endowments and schools singly. For example, the judge al-Harawi assigned for himself more governorship deputies than his predecessor al-Bulqini judge in order to take over all matters; they numbered about twenty deputies. In this way, he contradicts with the previous judge. Moreover, he followed a certain type of clothing and riding in processions, which was contrary to the custom in the conduct of judges followed in Egypt (Al-Maqrizi, 6, 1997: 432, 463, 468, 483; 7, 269). Thus, al-Harawi continued this course, taking advantage of the Sultan's respect and appreciation for him, until many people began to see this as derogation and a violation of customary morals, which was unworthy of the judges. So, people often filed complaints and submitted grievances to the Sultan, until

the Sultan changed his view of al-Harawi, then he was deposed in 822 AH/1419 AD (Ibn Iyas, 1983, 2:44-45; Al-Suyuti, 1991, 2:173-174; Al-Maqrizi, 1997, 6:471-472).

### CRITICISM AND PRAISE FOR EDUCATIONAL CIRCUMSTANCES, TEACHING TECHNIQUES AND METHODS

Scholars and poets did not hesitate to criticize or satirize whatever they saw as deflecting from virtue of morals and *shari'a*. The Andalusian writer and poet Shihab al-Din Ibn Abi Hijla (d. 776 AH/1375 AD) had written "*Diwan al-Ṣababa fi Akhbar al-'Ushshaq*" and other poetic and literary works; he always criticized many scholars (Ibn Iyas, 1983, ½,:146; Ibn Hajar al-'Asqalani, 1993, 1:329-331). Criticism and mockery were also directed to those who got high posts without having the required qualifications and those who were known for their lying and not applying religion and its manners, for example Najib al-Din Ibn al-Shuqayshiqa (d. 656 AH/ 1258 AD), who was famous for lying and weakness of his religion (Al-Nu'aymi, 2, 1988: 80-81; Ibn al-'Imad, 1992, 7:492; al-Maqrizi, 2002: 307).

Criticism and ridicule were also directed to the scholar 'Alam al-Din al-Isnwi (d. 777 AH/1376 AD), who came to power in Egypt without having sufficient knowledge and qualification (Al-Maqrizi, 4, 1997: 394). There were inordinate competition for getting high posts among the educational and religious leaders in Egypt and the Levant. For example, Ibrahim Ibn al-Mi'mar satirized the judge Taqiy al-Din al-Subki (d. 756 AH/1355 AD), who moved from Egypt to Syria, and took up the Shafi'i jurisdiction in Damascus, and there was a sharp disagreement between them about taking over educational and religious posts (Ibn Iyas, 1983, 1/1:556).

As for the judge, Kamal al-Din 'Umar Ibn al-'Adim al-Hanafi (d. 811 AH/1408 AD), he was prominent example in this context, where he was a senior judge and engaged in *fatwa* and teaching. Despite his scientific status and high posts, they did not prevent his rivals and critics from criticizing him, highlighting the disadvantages about his way of dealing in the *waqf* sale and controlling their funds (Ibn Taghri Birdi, 8, 1999: 262-264; Ibn Iyas, 1983, 2:791-792; Ibn al-'Imad, 1992, 9:137-138). Ibn al-'Adim held the post as a judge in Aleppo and dealt with the exploitation of endowments and caused sale and corruption of many of them. Then, he paid money and bribed to occupy the post of the chief justice in Egypt in 805 AH/1402 AD and settled there. He continued on this approach to exploit his post in order to control the endowments and their resources in Egypt as well. Al-Maqrizi described Ibn al-'Adim by saying: "he was a bad judge." In another place, al-Maqrizi stated in this context: "anyone who wanted to sell or buy *waqf*, went to Ibn al-'Adim with money or high standing, and then he gave them whatever they want...". The phenomenon of selling *waqf*, dealing in bribery and

buying posts in exchange for money in the Mamluk state were widespread during the time of Ibn al-'Adim (Al-Maqrizi, 1998, 3:268; Al-Maqrizi, 1997, 6:220; Ibn Taghri Birdi, 1999, 8:264; Al-Sakhawi, 1992, 6:65-66; Ibn Iyas, 1983, 12:667).

There were differences in teaching methods in the medieval ages between religious sciences (*al-'ulum al-naqliyya*) and philosophical sciences/ rational sciences (*al-'ulum al-'aqliyya*). While the study of religious sciences was mostly based on hearing, memorization, writing, explanation and interpretation; mental sciences were mainly based on research and scrutiny, interview, investigation, debate and discussion. Scholars' teaching methods in the late Mamluk period in Egypt and the Levant seemed to have confused and mixed between the various sciences, both transmitted and mental. This method of teaching led the Egyptian scholar Kamal al-Din al-'Idfuwi (d. 748 AH/1347 AD) to criticize these methods in religious sciences, and he also criticized teachers for their scientific level and teaching methods (Ibn Qadi Shuhba, 2, 1994: 519; Ibn Hajar al-'Asqalani, 1993, 1:535-536). Moreover, historians and poets mentioned the criticism of scholars who got in teaching posts without qualification or good management of the educational process, which negatively affects education and its staff, both scholars and students. Both Ibn Jama'a and al-'Almawi mentioned much criticism for teachers who did not have the competence in the profession and the ability to manage the educational process (Ibn Jama'a, 2012: 71; Al-'Almawi, 2004: 44).

In a poem by the historian Abu Shama al-Maqdisi (d. 665 AH/1267 AD), the sharpness of criticism for the conditions of education and schools in his reign appeared significantly. Abu Shama criticized teachers, students, those involved in the educational process and the way students rely on *Waqf* funds as scholarships. He also made sharp criticism for some scholars who control over the endowments of *madrasas* and their managements, teaching by cheating, getting closer to the rulers and the holders of authority, scholars' incompetence to educational posts, their lack of interest in science and their interest only in external manifestations (al-Maqdisi, 1, 1991: 91-102).

In light of this, majority of poets and scholars stressed on the importance of learners' good manners and ethics, as mentioned by the scholar Badr al-Din Ibn Jama'a in his famous book "*Tadhkirat al-Sami' wal-Mutakallim fi Adab al-'Alim wal-Muta'allim*". Many of these poets and scholars stated such ethics either in prose or poetry (Ibn Jama'a, 2012: 85-147; Al-Zurnuji, 1981: 76, 78-98; Al-'Almawi, 2004: 58-79; Al-Sam'ani, 1993: 183-381, 517). That's due to the fact that some scholars did not maintain the rules of ethics in lessons, education or discussions, and show their anger when discussing and arguing in lessons, as the scholar Abd al-'Aziz bin 'Ali al-Qudsi al-Hanbali (d. 846 AH/1442 AD) did with one of his students from Morocco (Al-Sakhawi, 1992, 4:224; Al-Najdi, 1996,

1:548).

## CONCLUSIONS

Mosques, *madrasas* and other religious and educational institutions had so much influence in the scientific renaissance and the flourishing of culture where the rulers and sultans in the medieval ages cared about the educational institutions. This renaissance gave the *ulama* strength and leadership posts in the management of institutions and scientific movement, which increased competition for these posts, and made *ulama*, writers and poets write about the description of the scientific movement and its leaders at this stage, whether it was praise, criticism, advice, recommendation to fix things, get closeness or flattery. Many poets and scholars had praised the rulers and sultans who established *madrasas* and other educational and religious institutions, allocated *waqfs* for their maintenance and disbursement, at the same time they vilified and criticized rulers, sultans and position owners who seized the funds of the endowments allocated to them and collected illegal funds. Poets not only criticized and praised rulers and sultans, but also wrote poems of criticism and praise for scholars. The praise poems for scholars were first to show gratitude them for their hard work, efforts and diligence in teaching knowledge and education spread, besides their leading, significant, religious and educational posts, and also for their interest in promotion of virtue and prevention of vice, this, in addition to praise scholar's behavioral and moral ethics. Critical poems had emerged and centered on the errors of some scholars, their negative scientific attitudes, religious posts, and their religious *fatwas* that left a sharp controversy among scholars. Criticism also extended to the appearance and the external view of scholars from dress or habits, which were distracting from the familiar and customary manners. A model of criticism appeared, which was concerned with the scholars who dealt with corruption and bribery, their interest in getting closer to the Sultans and rulers. Those scholars were known as the scholars of the Sultans or "worldly life scholars". The poets did not hesitate to direct criticism or vilification to what they see as deviation from morality, virtue and *shari'a*, also to those who obtain high posts without getting the knowledge that qualifies them. Some scholars, writers and historians had been critical of the scholars who got to teach without qualification or good management of the educational process and the deterioration of the conditions of education and schools. Besides, they criticized some scholars who took over the endowments of schools and their management and teaching by cheating. Unfortunately, this had a negative impact on education and its staff, scholars and students alike. They also criticized some scholars who did not have the rules of ethics in lessons, education or discussions a sense of virtuous and benign morals

towards the learners.

## CONFLICT OF INTERESTS

The authors have not declared any conflict of interest.

## REFERENCES

- Ahmad A'A (1979). *Al-Badhli wal-Bartala Zaman Salatin al-Mamalik*. Cairo: al-Hay'a al-Masriyya al-'Amma lil-Kitab.
- Al-'Almawi 'A (2004). *Al-Mu'id fi Adab al-Mufid wal-Mustafid*. Cairo: Maktabat al-Thaqafa al-Diniyya.
- Al-Dhahabi ShM (1999). *Tarikh al-Islam*. (vols. 35, 48). Beirut: Dar al-Kitab al-'Arabi 48:416-419
- Al-Ghazali AM (2020). *Al-Kifaya: Sharh Bidayat al-Hidaya*. Beirut: Dar al-Kutub al-'Ilmiyya.
- Al-Isnawi J'A (1987). *Tabaqat al-Shafi'iyya*. (vols. 1-2). Beirut: Dar al-Kutub al-'Ilmiyya.
- Al-Maqdisi 'AASh (1991). 'Uyūn al-Rawḍatayn fī Akhbār al-Dawlatayn: al-Nūriyya wal-Ṣalāhiyya. (vol. 1). Damascus: Wazārat al-Thaqāfa.
- Al-Maqdisi 'AASh (2002). Tarajim Rijal al-Qarnayn al-Sadis wal-Sabi'. Beirut: Dar al-Kutub al-'Ilmiyya.
- Al-Maqrizi TA (1997). *Al-Suluk fi Ma'rifat al-Duwal wal-Muluk*. (vols. 4, 6, 7). Beirut: Dar al-Kutub al-'Ilmiyya.
- Al-Maqrizi TA (1998). *Al-Mawa'iz wal-I'tibar fi Dhikr al-Khitat wal-Athar*. (vol. 3). Cairo: Maktabat Madbuli.
- Al-Najdi M'A (1996). *Al-Suhub al-Wabila 'ala Dara'ih al-Hanabila*. (vol. 1). Beirut: Mu'assasat al-Risala.
- Al-Nu'aymi 'AM (1988). *Al-Daris fi Tarikh al-Madaris*. (Vol. 1-2). Beirut: Dar al-Kitab al-Jadid.
- Al-Sakhawi ShM (1992). *Al-Daw' al-lāmi'*. Beirut: Dār al-Jīl.
- Al-Sam'ani 'AM (1993). *Adab al-Imla' wal-Istimla'*. Mecca: al-Matba'a al-Mahmudiyya.
- Al-Shukani M'A (1998). *Al-Badr al-Tali' bi-Mahasin man ba'da al-Qarn al-Sabi'*. (vols. 1-2). Beirut: Dar al-Kutub al-'Ilmiyya.
- Al-Subki T'A (1968). *Tabaqat al-Shafi'iyya al-Kubra*. (vol. 9). Cairo: Dar Ihya' al-Kutub al-'Arabiyya.
- Al-Suyuti J'A (1968). *Husn al-Muhadara fi Tarikh Misr wal-Qahira*. (vols. 1-2). Beirut: Dar al-Kutub al-'Ilmiyya.
- Al-Suyuti J'A (1991). *Ma Rawahu al-Asatin fi Dhamm al-Maji' ila al-Salatin*. Tanta: Dar al-Sahaba lil-Turath.
- Al-'Ulaymi M'A (1999). *Al-'Uns al-Jalil bi-Tarikh al-Quds wal-Khalil*. (vol. 2). Amman: Matba'at Dandis.
- Al-Zurnuji B (1981). *Ta'lim al-Muta'allim Tariq al-Ta'allum*. Beirut: al-Maktab al-Islami.
- Ibn 'Abd al-Birr Y'A (1994). *Jami' Bayan al-'Ilm wa-Fadlihi*. (Vol. 1-2). Al-Dammam: Dar Ibn al-Jawzi.
- Ibn 'Abd al-Birr Y'A (2008). *Bahjat al-Majalis wa-'Uns al-Majalis*. (vol. 1). Beirut: Dar al-Kutub al-'Ilmiyya.
- Ibn al-'Imad 'AA (1992). *Shadharat al-dhahab*. (vols. 7, 8, 9). Damascus: Dar Ibn Kathir.
- Ibn al-Wardi Z'U (1996). *Tarikh Ibn al-Wardi*. (vol. 2). Beirut: Dar al-Kutub al-'Ilmiyya.
- Ibn Hajar al-'Asqalani ShA (1993). *Al-Durar al-Kamina fi A'yan al-Mi'a al-Thamina*. (4 vols.). Beirut: Dar al-Jil.
- Ibn Hajar al-'Asqalani ShA (1969-1998). *Inba' al-Ghumr bi-Abna' al-'Umr*. (vols. 1-4). Cairo: Lajnat Ihya' al-Turath al-Islami.
- Ibn Iyas MA (1983). *Bada'i' al-Zuhur fi Waqa'i' al-Duhur*. (vols. 1-2). Cairo: al-Hay'a al-Masriyya al-'Amma lil-Kitab.
- Ibn Jama'a BM (2012). *Tadhkirat al-Sami' wal-Mutakallim fi Adab al-'Alim wal-Muta'allim*. Beirut: Dar al-Basha'ir al-Islamiyya.
- Ibn Kathir I'U (1988). *Al-Bidaya wal-Nihaya*. (vols. 12-14). Beirut, Maktabat al-Ma'arif.
- Ibn Qadi Shuhba (1977, 1994). *Tarikh Ibn Qadi Shuhba*. (vols. 1, 2). Damascus: al-Ma'had al-'Ilmi al-Faransi.
- Ibn Qadi Shuhba (1978-1980). *Tabaqat al-Shafi'iyya*. (vols. 1-4). Haydar-Abad: Da'irat al-Ma'arif al-'Uthmaniyya.
- Ibn Taghri Birdi JY (1970). *Al-Nujum al-Zahira fi Muluk Misr wal-Qahira*. (vols. 7-15). Cairo: Dar al-Kutub.
- Ibn Taghri Birdi JY (1984-2002). *Al-Manhal al-Safi wal-Mustawfi ba'da al-Wafi*. (vols. 2, 7, 8). Cairo: Dar al-Kutub al-Masriyya.
- Mahamid H (2013). *Waqf, Education and Politics in Late Medieval Syria*. Germany: Lap Lambert Academic Publishing.
- Salibi KS (1958). "The Banu Jamā'a: A Dynasty of Shafi'ite Jurists in Mamluk Period". *Studia Islamica* 9, pp. 97-109.

*Full Length Research Paper*

# **The discovery teaching of the problem of finding the shortest distance with the help of Geogebra software in Vietnam**

**Ngoc-Giang Nguyen**

Department of Economic Mathematics, Banking University of Ho Chi Minh City, 36 Ton That Dam, Nguyen Thai Binh Ward, District 1, Ho Chi Minh City, Vietnam.

Received 24 June, 2021, Accepted 23 July, 2021

Vietnam today is having solid innovations in the fields of science, technology, economics, and education. In particular, the Mathematical General Education program launched in 2018 has emphasized the exploitation of information technology in teaching. GeoGebra software is taught right from the 6th grade. GeoGebra software has many advantages in problems related to motion such as locus, modeling, and especially in finding the shortest path. We have found that the discovery teaching method proves to have outstanding advantages in teaching this shortest path problem. Our research focus on understanding the perspectives of discovery teaching, the discovery teaching process, the pros and cons of the discovery teaching method, illustrating the application of GeoGebra software in the discovery teaching of finding the shortest distance. Using essential research methods such as theoretical research, investigation, survey, and descriptive statistics with the help of SPSS version 20 software for 49 students grade 12th, we found that students felt very interested in the new teaching method. Students showed excitement and enthusiasm in lessons to find the shortest distance with the help of GeoGebra software. The assessment results show that students make more progress when applying GeoGebra to teaching than traditional teaching methods.

**Key words:** Discovery teaching, shortest distance, GeoGebra.

## **INTRODUCTION**

Discovery teaching is a learner-centered teaching method (Le, 2007; Nguyen, 2014). Learners only really progress and develop when they participate in knowledge construction themselves (Tran, 2003). They build their knowledge through practical experience activities.

Learning is a sequence of active learner activities (Nguyen, 2007). Based on students' knowledge base, teachers guide and supplement rather than impose knowledge. Through these guiding and supporting activities, students form understanding. Discovery

E-mail: [nguyennngocgiang.net@gmail.com](mailto:nguyennngocgiang.net@gmail.com).

Author(s) agree that this article remain permanently open access under the terms of the [Creative Commons Attribution License 4.0 International License](https://creativecommons.org/licenses/by/4.0/)

teaching is a process, not an outcome. It is not a rigid, dogmatic, immutable teaching method (Tran, 2004). Discovery teaching helps students to drill down and solve problems better in real-life situations. Teaching activities of this method are divergent. Students are not the ones who answer the questions by heart. They must explore, observe and draw new knowledge by themselves (Phan, 2013). These ones will start from a task of teaching to exploit and transform to expand their knowledge gradually. Learners will slowly dissect knowledge units. After that, it will be aggregated to obtain substantive results. In particular, the discovery teaching method proves to be effective when working in groups or applying information technology to teaching. Information technology activities require students to self-study problems, analyze problems, explain and clarify issues in learning. These activities are the advantages of information technology in general and GeoGebra software in particular (GeoGebra, 2021). Thanks to the advantage of dynamic geometry software, GeoGebra software can build, move, create traces, predict results, verify, discover solutions that the results are known immediately, so it is very effective to apply in the problem of finding the shortest distance. Students can rely on the results found on GeoGebra software to draw their results. From the prediction results on GeoGebra software, learners rely on that, mobilizing their available knowledge and experience to find the solution themselves. This learning process is "reversed" learning. Instead of starting from the original data, learners find a solution for it and then draw the conclusion of the problem; now, learners do the opposite. It is a new feature in teaching, but teaching methods with traditional tools such as blackboards, white chalk, rulers, and compasses can hardly do. From the above comments, in this article, we focus on answering the following four questions:

1. What are some of the views and concepts about discovery teaching?
2. What are the advantages and disadvantages of discovery teaching?
3. What are the steps involved in the discovery teaching process with the help of GeoGebra software?
4. What are the specific examples of the application of GeoGebra software in discovery teaching to find the shortest distance?

## METHODOLOGY

Discovery teaching is a teaching method based on constructivism. Learners participate in open hands-on activities to solve real-life problems. Learners connect new information with existing knowledge in an organized and systematic way. This learning requires learners to mobilize higher-order thinking (Rooney, 2009). This one is a student-centered approach. This way of teaching both

improves students' learning outcomes and develops higher-order skills. If teachers aim for a strong link between teaching and research, then teachers should adopt a discovery teaching method. The method is the process of seeking new knowledge and understanding (Spronken-Smith and Walker, 2010). It plays an essential and active role in student learning. This way of teaching creates curiosity, imagination and encourages students to interact and explore knowledge and science through experiential activities (Harlen, 2013).

Discovery teaching is a form of teaching in which students engage in learning activities, solve unsolved problems, and construct, analyze, and debate mathematical arguments. From there, students draw new knowledge on their own (Laursen et al., 2014). In this one, learners engage in problem-solving activities as experts. They collaboratively discover with others in an environment without or with very little guidance and support from the teacher. (Kirschner et al., 2004). This method is one of the modern and active forms of teaching that helps students make the right decisions and apply scientific knowledge to solve problems. It is the best way to gain scientific understanding because it allows students to discuss and debate scientific ideas. It is how scientists practice, evaluate ideas and draw conclusions (Gormally et al., 2009).

In discovery teaching, students will learn content such as knowledge, skills, and reasoning by actively participating in meaningful research, interpreting, and communicating their ideas. Teachers play an important role in facilitating this learning process and providing content knowledge when needed (Hmelo-Silver et al., 2007). This method is a practical method for establishing connections between prior knowledge and scientific descriptions of the natural world. Students should be allowed to understand how to do scientific research (Panasan and Nuangchalem, 2010). This one helps students explore mathematical problems, propose and test conjectures, develop proofs or solutions, and explain students' ideas. As students learn new concepts through debate, they also see math as a creative human endeavor to contribute. It is consistent with the socio-constructive view of learning. It emphasizes the construction of personal knowledge supported by social interactions (Kogan and Laursen, 2014).

Discovery teaching increases practice time, reduces theoretical discussion, and helps improve critical thinking. This method has positive effects, assisting students to gain a deep understanding and achieve high academic achievement (Friesen and Scott, 2013). The one has many different perspectives and research directions. This method is distinguished by the type and complexity of problems and the degree of student-centered learning (Schoenfeld and Kilpatrick, 2013). It is an active teaching method. Students are given a carefully choreographed mathematical task sequence and asked to solve and understand them, either individually or in groups (Ernst et al., 2017).

Discovery teaching promotes positivity in science and math education. The one is a teaching method that fosters necessary competencies and attitudes for everyone in today's increasingly technology-based society (Harlen, 2013). This method is an approach to teaching that offers research-intensive learning opportunities. The one guides students to explore or reinvent essential math concepts through carefully formulated tasks. This teaching method requires students to have the habit of thinking like a practicing mathematician, developing the ability to guess, experiment, create, and communicate. Therefore, discovery teaching develops the critical process, supporting in-depth research on the topic to be explored. It can promote persistence, independence, and creative application of mathematical knowledge in practice (Laursen et al., 2015). It is the ability to think and work scientifically and is encouraged by science and education leaders

worldwide. Scientifically minded people are important to science, technology, and society because they are always curious, always trying to understand the world around them, and become lifelong learners. Therefore, education must be taught to allow students to make personal, social, and economic decisions. It is the most appropriate teaching method for this claim (Madhuri et al., 2012).

Discovery teaching is a teaching method in which students actively explore information by applying scientific discoveries to real-life contexts. The one is how students approach the natural world through questions, tasks, tests, and assessments to gain a new understanding. Students create knowledge by activating and restructuring knowledge. The exploratory learning environment also requires students to be active in the learning and interacting process (De Jong, 2006). This method not only helps learners discover new knowledge but also helps students develop creative thinking (Vu, 2017). Students' discovery activity in learning is not a spontaneous process but a cognitive approach with the guidance of teachers to capture human knowledge (Le, 2017).

Discovery activity in discovery teaching is not a groping process like scientific researchers but a process of exploratory activities with the guidance of teachers. The teacher skillfully puts the student in the position of the rediscoverer of knowledge. Teachers do not give presentations to students directly, but students must acquire new knowledge through experiential activities (Tran, 2011). Discovery teaching emphasizes ways to find new knowledge based on old knowledge and experiences of students. It emphasizes the learning process, not the learning outcomes. Students acquire knowledge on their own through teacher's activities. Questions and questioning are essential elements of discovery teaching. The result of this one is that students develop knowledge and skills and grasp the methods of acquiring the knowledge and skills (Le, 2012).

From the points of view of the above, we draw a brief comment. Discovery teaching is a teaching method based on constructivism. It is an active and student-centered teaching method. Learners in this one must always acquire new knowledge by themselves through questions and the teacher's guidance. It is a teaching method that emphasizes the whole learning process, not just the learning outcome. Learners learn knowledge, skills, and promote progressive attitudes and learn how to get to those knowledge, skills, and attitudes.

## RESULTS

### Advantages and limitations of discovery teaching

Discovery teaching is an active teaching method. It is a teaching method that promotes the potential of the learners.

However, this method also has certain advantages and limitations.

#### Advantages

1. Pleasure and satisfaction in finding out something for yourself that you want to know;
2. Gaining knowledge by yourself is more effective than being taught directly by a teacher;
3. Stimulate curiosity about the world around;
4. Develop newer and bigger ideas about the world

around you;

5. Develop the necessary skills in scientific research through participation in it;
6. Realize that scholarly learning involves discussing, working with, and learning from others or through documentation;
7. To understand the discovery problem, the discoverer must make an effort (Harlen, 2013).

#### Limitations

1. Potentially confusing students if they do not have an initial knowledge base.
2. There are practical limitations when schools do not consider it the primary teaching method for learning lessons.
3. Spending much time doing lesson activities (e.g., math activities), so there won't be enough time for students to "discover" everything during the student's school year.
4. Requires teachers to prepare many things for correcting, lots of feedback on students making mistakes (trial and error process).
5. It can become a barrier because of many essential skills and essential information that all students should learn.
6. If discovery teaching is implemented as the most crucial educational theory, there will be a tendency to create an incomplete education.
7. Discovery teaching in the traditional classroom is only possible with a small number of students, not interacting with students in different geographical areas, such as students in this province, another province, or this country, the other country. Therefore, the interactive environment in traditional discovery teaching is limited.
8. Discovery teaching in traditional classrooms with many students does not have enough experts to assist in the immediate response phases. When students choose the wrong option, traditional discovery teaching does not immediately provide additional information or guidance.
9. Traditional discovery teaching often requires a teacher to perform the teaching phase. Students explore according to the activities and requirements of the teacher (Nguyen, 2016).

### Discovery teaching process with the help of GeoGebra software

Based on the discovery teaching process proposed by Levy and Petrulis (2012), including identifying, pursuing, producing, and authoring steps, we offer the discovery teaching process with the help of GeoGebra software as follows:

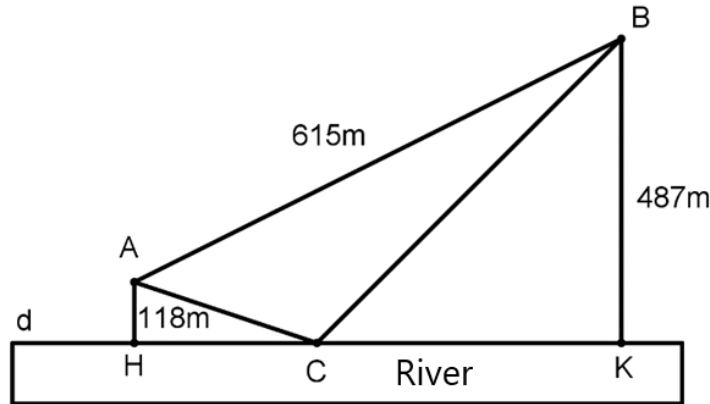

Figure 1. The minimum distance (Personal Collection) (Trinh, 2020).

**Step 1. Identify the problem to be discovered with the use of GeoGebra software**

Teachers ask questions and ask students to use GeoGebra software actively to explore solutions.

**Step 2. Build shapes on GeoGebra software**

Students build shapes on GeoGebra software, move points and objects to different positions. From there, we find the results as well as verify the students' predictions.

**Step 3. Solve the math**

From the prediction results on GeoGebra software, we draw the corresponding solution.

**Step 4. Conclusion**

Conclude problem solutions.

**Step 5. Deepen the problem**

Find many ways to solve the problem, expand the problem, and find out similar issues with the problem being discovered, thereby forming new results and new problems.

**Example illustrating the application of GeoGebra software in discovery teaching of finding the shortest distance**

**Example 1**

There are two locations, A and B, on the same side of the

riverbank  $d$  as shown in Figure 1. The distance from A to the riverbank is 118m, and the distance from B to the riverbank is 487m. In addition, the distance between A and B is 615m. A person goes from location A to the riverbank (A, B side) to get water and then goes back to position B. What is the minimum distance that person goes from A to B (with stops by the riverbank)? (unit m).

Generalizing Example 1, we get the following Héron problem:

**Example 2 (Héron Problem)**

In the plane, given a line  $d$  and two points A and B on the same side of the line. On the given line, find a point C such that the sum of the distances from that point C to two points A and B is the smallest (Nguyen et al., 2020).





In the following, we will use GeoGebra software in discovery teaching to solve this shortest path problem.

**Step 1. Identify the problem to be discovered with the help of GeoGebra software**

Teacher: Please build the shape and find point C, so that  $CA + CB$  is the smallest on GeoGebra software.

**Step 2. Build the shape on GeoGebra software**

Students:

1. Construct a straight line  $d$ : 
2. Draw point A and point B on the same side with  $d$ : 
3. Draw point C on the line  $d$ : 
4. Connect CA, CB: 

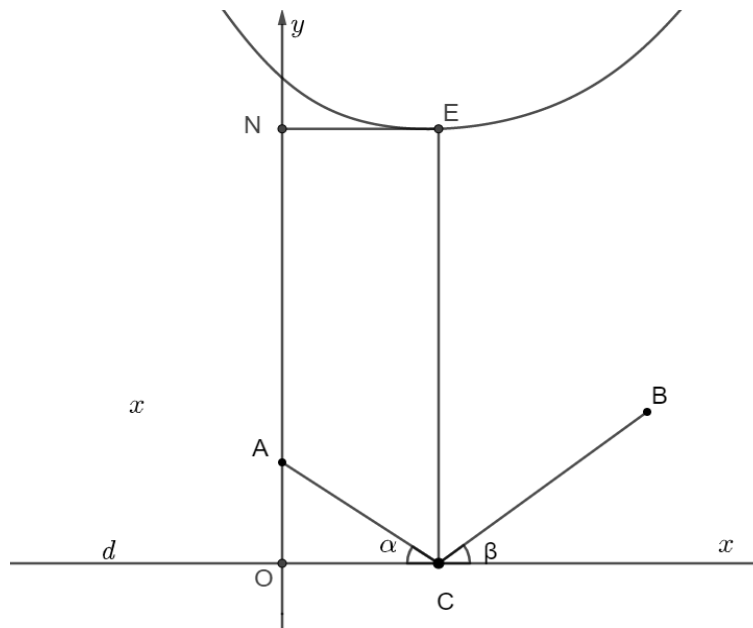
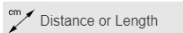
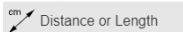

Figure 2. Graph of Héron problem (Personal Collection).

5. Measure the length of the line segments  $CA, CB$ :



6. Measure the total length of the line segments  $CA + CB$ :



7. Construct a system of perpendicular axes  $O_{xy}$ , so that  $O_y$  contains  $A$  and  $O_x$  belongs to  $d$ .

8. Draw on  $O_y$  a point  $N$  so that  $ON$  is equal to the sum of the lengths of the line segments  $CA + CB$ .

9. Suppose  $E$  is the intersection of the line perpendicular to  $O_y$  at  $N$  and the line perpendicular to  $O_x$  at  $C$  (coordinates of point  $E$  represent the sum of the lengths of the line segments  $CA + CB$ ).

10. Create a trace for  $E$ , move  $C$  we get a trace of point  $E$  (Nguyen, 2019).

Teacher: The outstanding advantage that GeoGebra

dynamic geometry software has, but cannot be done by ordinary mathematical thinking, is that we can move point  $C$  on  $d$  so that the coordinates of point  $E$  reach the minimum value. Now through observation, we see that the angles  $ACd$  and  $BCx$  are equal (Figure 2).

**Step 3. Solve the math**

Teacher: We denote distances and angles as shown in Figure 3.

When  $(CA + CB)_{\min}$ ,

then  $\alpha = \beta$ ,

$\tan \alpha = \tan \beta$ .

What relation do you get?

Students:  $\tan \alpha = \tan \beta \Leftrightarrow \frac{a}{x} = \frac{b}{c-x} \Leftrightarrow ac = (a+b)x \Leftrightarrow x = \frac{ac}{a+b}$ .

Teacher: Now  $(CA + CB)_{\min} = ?$

Students:  $(CA + CB)_{\min} = \sqrt{a^2 + \left(\frac{ac}{a+b}\right)^2} + \sqrt{b^2 + \left(c - \frac{ac}{a+b}\right)^2} = \sqrt{c^2 + (a+b)^2}$ .

Teacher: Prove that for every point  $C$ ,  $CA + CB$  is always  $(CA + CB)_{\min} = \sqrt{a^2 + (b+c)^2}$ ?



greater than or equal to Students: We will prove:

$$\begin{aligned}
 & \sqrt{a^2 + x^2} + \sqrt{b^2 + (c - x)^2} \geq \sqrt{(a + b)^2 + c^2} \\
 \Leftrightarrow & a^2 + x^2 + b^2 + c^2 - 2cx + x^2 + 2\sqrt{(a^2 + x^2)(b^2 + (c - x)^2)} \geq a^2 + b^2 + c^2 + 2ab \\
 \Leftrightarrow & \sqrt{(a^2 + x^2)(b^2 + (c - x)^2)} \geq ab + x(c - x) \\
 \Leftrightarrow & a^2b^2 + a^2(c - x)^2 + x^2b^2 + x^2(c - x)^2 \geq a^2b^2 + x^2(c - x)^2 + 2abx(c - x) \\
 \Leftrightarrow & a^2(c - x)^2 + x^2b^2 \geq 2abx(c - x) \\
 \Leftrightarrow & (a(c - x) - bx)^2 \geq 0.
 \end{aligned}$$

Teacher: So building shapes on GeoGebra gives us an important mathematical approach that we would not usually be able to do. That is, it is possible to create a trace for point  $E$ . From the trace of point  $E$ , we can move point  $C$  to a position so that the coordinates of point  $E$  are the smallest. From moving point  $C$  so that the coordinates of point  $E$  are the smallest, we will infer how to solve the problem. Like it or not, this is always a great mathematical thought. It gives us immediate access to the results. From the result, we will deduce the solution. Obviously, this is a bit of a paradox. But the paradox makes perfect sense thanks to the development of informatics. This teaching method is also known as

reverse teaching (Nguyen, 2019).

Teacher: When  $\alpha = \beta$ , let  $A'$  be the symmetry point of  $A$  through  $d$ , we will have  $A', C, D$  collinear. From this comment, draw the result of example 1 (Figure 4):

Students:

Let  $A'$  be the point of symmetry of  $A$  with respect to  $d$ . Let the intersection of the line through  $A'$  perpendicular to  $AA'$  and  $BK$  be  $B'$ . Let  $C$  be a point in  $HK$ . Then we have  $AC + CB = CA' + CB \geq A'B$ .

Hence:

$$\begin{aligned}
 (AC + CB)_{\min} &= A'B \\
 &= \sqrt{BB'^2 + A'B'^2} \\
 &= \sqrt{(BK + HA')^2 + AB^2 - (BK - AH)^2} \\
 \Rightarrow A'B &= \sqrt{(487 + 118)^2 + 615^2 - (487 - 118)^2} \\
 &= \sqrt{608089} \approx 779,800612m.
 \end{aligned}$$

#### Step 4. Conclusion

So the minimum distance that person goes from  $A$  to  $B$  (with a stop at the river bank) is **779,800612m**.

#### Step 5. Deepen the problem

Teacher: In addition to mathematical solutions, the Héron problem has many other solutions.

Students: Listen and absorb ideas (Figure 5).

Teacher:

##### Solution 2

Moving along the curved line  $ACB$  can be considered light traveling from  $A$  to "flat mirror"  $d$  (line  $d$  acts as a flat mirror); after reflecting on the mirror, the reflected ray passes through point  $B$ .

According to the law of light reflection, we immediately get the solution of the problem when  $C$  coincides with  $C'$ . Now  $AC'N = NC'B$  (Nguyen, 2019).

This solution shows the physical nature of the mathematical problem. However, this is not the only physical solution. We can solve this problem by other physical methods as follows:

##### Solution 3

We consider a weightless  $C$  ring that can slide without friction along a horizontal  $d$ -axis. At the  $C$  end, there are two threads connected. Each of these threads loops around a pulley (at  $A$  and  $B$ , respectively), and at the other end of the thread hang heavy objects of the same mass  $C_1$  and  $C_2$  respectively (Figure 6). We also

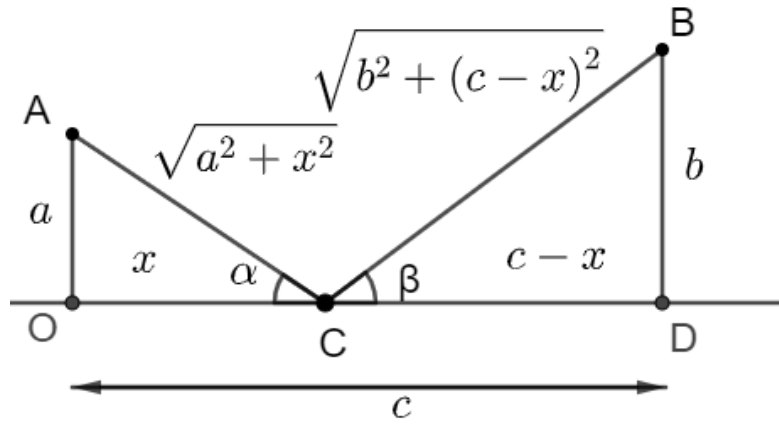

Figure 3. Mathematical solution (Personal Collection).

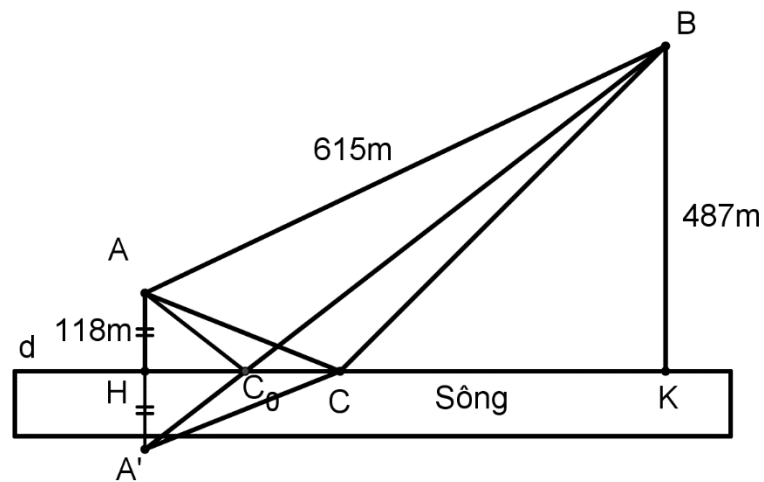

Figure 4. Real solution (Personal Collection).

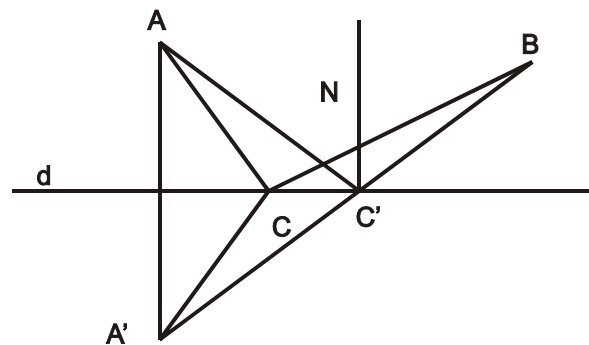

Figure 5. Solution by the law of light reflection (Personal Collection).

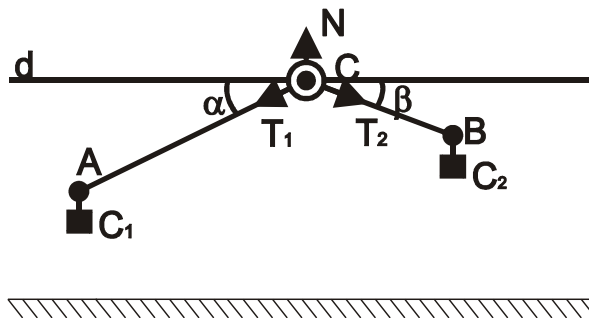

Figure 6. Mechanical solution (Personal Collection).

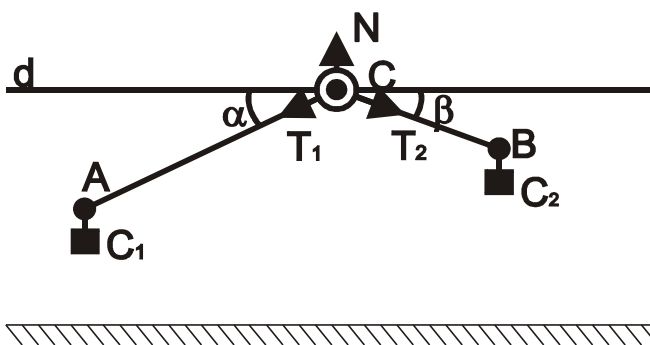

Figure 7. Tension forces (Personal Collection).

assume the usual simplification conditions: the shaft is absolutely rigid, threads are absolutely soft but not elongated, regardless of friction, the weight of threads and reaction of their cornering, size of the pulleys, and the ring. We need to find the position of the C-ring on rod  $d$  so that the whole mechanical system is in equilibrium.

Indeed, the two heavy objects must be suspended as low as possible (that is, the system's potential energy must be minimized). Hence it follows that the sum of,  $AC_1 \cdot C_1 + BC_2 \cdot C_2$  must be maximal. Since the length of each string remains the same, the sum of  $AC \cdot C_1 + BC \cdot C_2$  must be minimized.

At the equilibrium position of the system, the forces acting on the ring C are zero. Therefore, C is subjected to the tension forces of the threads  $\vec{T}_1$  and  $\vec{T}_2$  ( $|\vec{T}_1| = |\vec{T}_2|$  - (the heavy objects pull the threads with equal forces, the tension due to the weights is not reduced by friction in the pulleys but is transmitted completely) and reaction  $\vec{N}$  (Figure 7).

Since  $\vec{N} + \vec{T}_1 + \vec{T}_2 = \vec{0}$  and  $\vec{N} \perp d$ , the projection on the line  $d$  gives us  $|\vec{T}_1| \cos \alpha = |\vec{T}_2| \cos \beta$ , from which

$\alpha = \beta$ . We also get the same result as solution 1.

Here, we need to explain more why we project  $\vec{N} + \vec{T}_1 + \vec{T}_2 = \vec{0}$  onto the line  $d$  ( $\vec{N} \perp d$ ) and get the relation  $|\vec{T}_1| \cos \alpha = |\vec{T}_2| \cos \beta$ . Because the tension forces cannot pull the ring back vertically because the  $d$  axis passes through the absolutely rigid ring (the reaction  $\vec{N}$  of the shaft can be of arbitrary magnitude), in addition, the horizontal component forces of those two forces, having opposite directions, must cancel each other out, must be equal in magnitude. Or we have the relation  $|\vec{T}_1| \cos \alpha = |\vec{T}_2| \cos \beta$ . It coincides with the argument above) (Nguyen, 2019).

Teacher: After explaining the Héron problem with methods in different fields, we realize one thing: mathematics is beautiful. Mathematics, informatics, and physics are not separate from each other but are closely linked, dialectically not separate. One area illuminates the other and vice versa.

Teacher: Extend point C to the line segment CD moving on  $d$ . Please state this extended problem.

Students: Give the extended problem.

**Example 3** (Generalization of the Héron problem)

Given two fixed points, A and B lie on the same side of the line d. The segment CD on the line d has a constant length and moves along this line. Find the position of CD so that the perimeter of the quadrilateral ABCD is the smallest.

This problem is a generalization of the Héron problem. Does it have anything to do with the Héron problem? Can we turn this problem into a Héron problem? The answer is yes. Before going to the solution closely related to the Héron problem in the following section, we build the model on GeoGebra software to find the position CD on d so that the perimeter of quadrilateral ABCD is minimal. Since the perimeter of quadrilateral ABCD is the smallest if and only if CA + DB is the smallest, we construct the following:



Step 1. Identify the problem to be discovered with the help of GeoGebra software.

Teacher: Build the shape and find the points C and D so that CA + DB is the smallest on GeoGebra software?

Step 2. Build the shape on GeoGebra software

Students:

Step 1. Build the shape

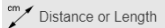
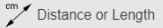
- Construct a straight line d: 
- Construct a line segment CD of constant length sliding over d: 
- Construct two points A and B on the same side of the line d: 
- Connect CA, BD.
- Measure the length of the line segments CA, DB: 
- Measure the total length of the line segments CA + DB: 
- Construct a system of perpendicular axes Oxy so that Oy passes through point A and Ox lies on line d.
- Construct on Oy a point N so that ON is equal to the sum of the lengths of the line segments CA + DB.
- Let E be the intersection of the line perpendicular to Oy at N and perpendicular to Ox at C (coordinates of point E represent the sum of the lengths of the line segments CA + CB).

Step 2. Make a trace

- Create a trace for E; moving C, we get a trace of point E.

We move point C on d so that the coordinates of point E reach the minimum value. Now through observation, we see that angle ACd and B'Cx are equal (B' is the point so that  $\overline{B'B} = \overline{CD}$ ) (Figure 8).

Step 3. Solve the problem

We see that example 3 and example 2 are closely related. How do we bring example 3 to example 2? We consider the translation  $T_{\overline{DC}} : B \mapsto B', D \mapsto C$ . Now, CA + DB = CA + CB'. So we return to example 2. We have the same solution as for example 2 as follows:

1. Draw point B' so that  $\overline{BB'} = \overline{DC}$ .
2. Connect CA, DB.
3. Let A' be the point of symmetry of A with respect to d. Join A'B and cut d at C'. Connect C'A, C'B'.
4. Draw point D' so that  $\overline{B'B} = \overline{C'D'}$ , then C'D' is the position to be erected.  
 $CA + BD = CA + CB' = CA' + CB' \geq A'B' = A'C' + C'B = C'A + C'B = C'A + D'B$ . (Nguyen, 2019) (Figure 9).

Step 4. Conclusion

So C'D' is the position to be erected.

**DISCUSSION**

**Purpose, requirements, and content of the pedagogical experiment**

**Time, object**

The pedagogical experiment was conducted at Binh Chanh High School (Binh Chanh District, Ho Chi Minh City) for the 2020-2021 school year.

- Experimental class 12A1 includes 24 pupils. Math teacher: Huynh Thi Thanh Binh.
- Control class 12A2 includes 25 pupils. Math teacher: Huynh Thi Thanh Binh

**Experimental process**

Investigate and evaluate the learning situation of students in the experimental class and the control class. Prepare materials and experimental lesson plans. The teacher conducts teaching according to the compiled lesson plan. Monitor learning attitude, test-taking skills, ability to

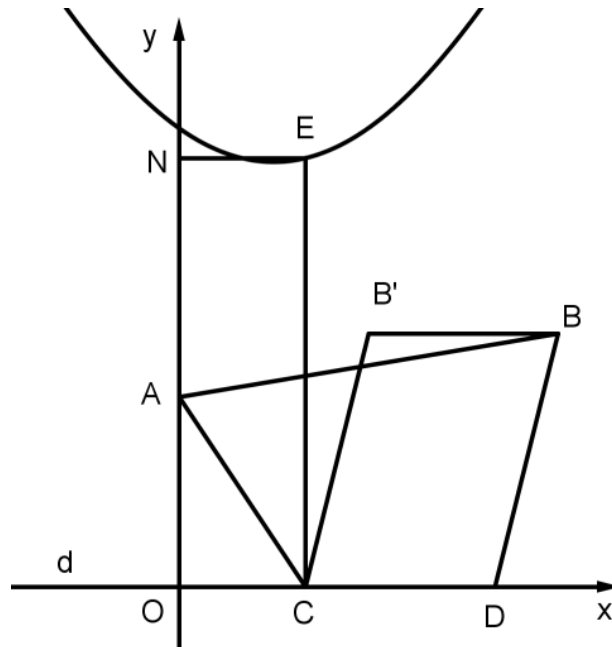

Figure 8. Graph (Personal Collection).

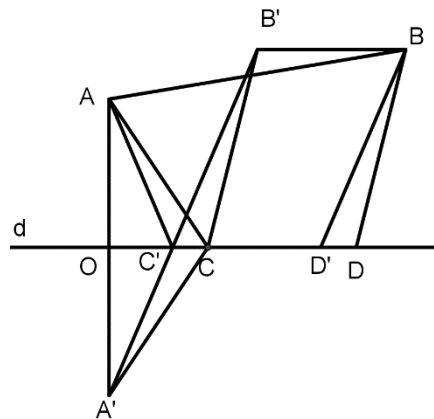

Figure 9. The smallest perimeter (Personal Collection).

receive general knowledge of the whole class. After teaching, the teacher gives the experimental class and the control class a 45-minute test.

**Empirical evaluation method**

We observe the classroom: to receive students' feedback on the lesson about interest, positive attitude, awareness level, and ability to apply. After that, Interview the

students: talk with students to clarify information about the level of interest of measures that are difficult to determine through observation.

In addition, we conduct interviews with teachers to know the teachers' evaluations and comments about the students' interest and awareness levels in the experiment. We give essay test: aims to assess students' ability to acquire knowledge through the lesson. We test individual understanding of the experimental and control classes through a test in the form of an essay after the

**Table 1.** Frequency distribution table of math test scores of two classes (Personal Collection).

		Experimental math test scores										Total
		5.5	6.0	6.5	7.0	7.5	8.0	8.5	9.0	9.5	10.0	
Class	E	0	1	1	4	4	5	4	3	1	1	24
	C	2	3	3	4	4	3	3	2	1	0	25
Total		2	4	4	8	8	8	7	5	2	1	49

**Table 2.** Table of the characteristics parameters of statistics of test scores of two classes (Personal Collection).

Class	Mean	Variance	Std. Deviation
E	7.96	.93	.97
C	7.34	1.27	1.12

experiment.

The content of the test is based on the lesson's objectives according to the lesson plan. We pay special attention to the exercises to evaluate the effectiveness of using the students' ability to detect and solve problems. The scores of the tests are scored on a 10-point scale. Next we use mathematical, statistical method: aims to know the mean, variance, and standard deviation. From there, we know the significance of the numbers through statistics. The statistical software used here is SPSS version 20 software.

In this method, we evaluate the average score of the experimental class and the control class in the first semester, the score of the most recent test before the experiment, and the score of the experimental test on the actual math topic in grade 12 through the following tables.

The first is the score frequency table of the two classes. The second is the histogram of the scores of the two classes. Next, the third is a table of characteristic values (including mean, variance, standard deviation). Finally, the Independent Samples T-Test panel tests whether there is a statistically significant difference between the points in the two classes.

**Analysis of pedagogical experiments**

To test the feasibility and evaluate the effectiveness of the measures, we asked the teacher to conduct a 45-min test for students of the experimental class and the control class. Through a quantitative analysis based on the test results, we obtained the frequency distribution table of experimental math test scores of the experimental class and the control class as follows (Table 1).

We test the normal distribution and find that the distribution of the experimental scores is normally distributed (Chart 1).

From the data in Table 1, we have Chart 2 to compare the scores of the test results of the two classes.

Looking at Chart 2, we can see that the heights of the score columns and the distribution of points of the two classes are different. The scores of the experimental class are from 6.0-10 points or more, and most are 7.0-9.0 points. The score distribution of the control class is from 5.5-9.5 points, and the majority is from 6.0-8.5.

In addition, we also obtain the characteristic parameters of statistics as in Table 2.

Reading the above test results, we have the average score of the two classes:  $\bar{X}_E = 7.96$ ;  $\bar{X}_C = 7.34$ .

Variance:  $S_E^2 = 0.93$ ;  $S_C^2 = 1.27$ .

Comment: There is a big difference between the mean scores of the two classes.

The average score of the experimental class is higher; the experimental class's standard deviation and variance are lower, so the concentration around the mean is higher than that of the control class. Therefore, we can say that the score of the experimental class is higher than that of the control class.

To accurately assess the difference (or the big, small) between the mean scores of the two experimental classes, we test the mean between the two classes, with a significance level  $\alpha = 0,05$  through Table 3 with two the following assumptions:

Assumption  $H_0$ : "The mean scores of experimental and control classes are similar."

$H_1$ : "The average score of the experimental class is higher than that of the control class."

- Levene test has a value of  $Sig. = 0.324 > \alpha = 0,05$ , so the variances of the two classes are almost equal, using the results of the Independent-samples T-test corresponding to the case where the equal variances of

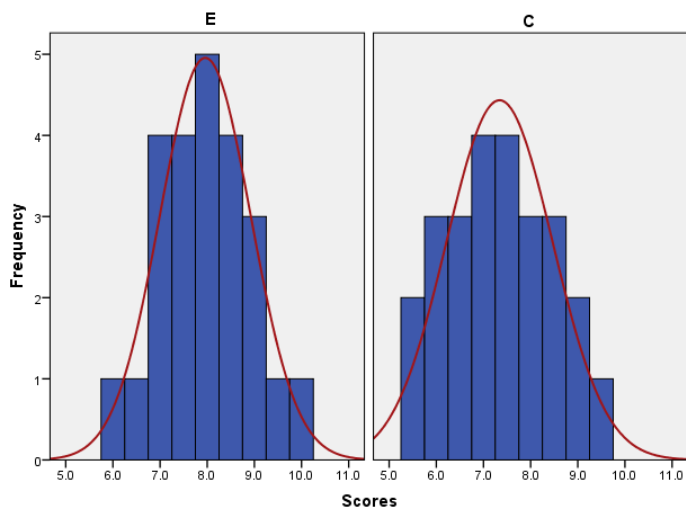

**Chart 1.** Distribution of math test scores of two classes (Personal Collection).

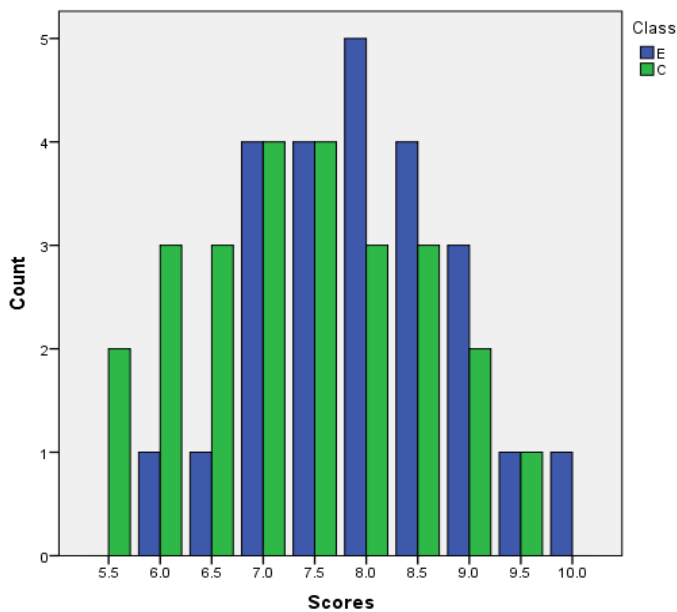

**Chart 2.** Column chart comparing test scores of two classes (Personal Collection).

the two samples are assumed.  
 - Independent-samples T-test, we have  $Sig.(2-tailed) = 0.045 < \alpha = 0.05$ , so we reject hypothesis  $H_0$ , accept hypothesis  $H_1$ . The mean score of the experimental class is higher than that of the control class at the 5% level of significance.

Thus, by the test method between classes with equivalent academic ability, the results show that after being taught according to the experimental lesson plan, the experimental class has better results, the average score is higher than that of the control class. Thus, it can be seen that the experimental measures applied to the

**Table 3.** Average T-test table of test scores of two classes (Personal collection).

		Independent samples test									
		Levene's test for equality of variances		t-Test for equality of means							
		F	Sig.	t	df	Sig. (2-tailed)	Mean Difference	Std. Error Difference	95% Confidence interval of the difference		
										Lower	Upper
Experi-mental test scores	Equal variances assumed	0.995	0.324	2.061	47	0.045	0.6183	0.3001	0.0147	1.2220	
	Equal variances not assumed			2.067	46.440	0.044	0.6183	0.2991	0.0164	1.2203	

experimental class are entirely feasible and effective in teaching.

**CONCLUSION AND RECOMMENDATIONS**

In discovery teaching, learners are not passive people. Learners actively explore on their own, ask questions to teachers, and acquire knowledge by themselves.

Discovery teaching with the help of GeoGebra teaching is an effective method of stimulating learners to participate in the learning process. This method is suitable when used in conjunction with mathematical software, including GeoGebra. Discovery teaching with the help of GeoGebra software requires teachers to be brave. Teachers, through leading questions, have pedagogical intentions to help learners answer. From those answers, learners will construct knowledge software is a teaching method that requires time, effort, and money. However, the effectiveness of discovery teaching is much higher than that of traditional teaching methods. It is a student-centered teaching method. All the teaching process revolves around the student. Therefore, students are the most important subject of discovery teaching. Discovery teaching with the help of GeoGebra software helps students sustainably acquire knowledge. Discovery teaching focuses on the teaching process rather than testing and evaluating through grades.

**CONFLICT OF INTERESTS**

The author has not declared any conflict of interests.

**REFERENCES**

De Jong T (2006). Technological advances in inquiry learning. *Science* 312:532-533.  
 Ernst DC, Hodge A, Yoshinobu S (2017). What Is Inquiry-Based Learning? *Doceamus* 64(6):570-574.

Friesen S, Scott D (2013). Inquiry-Based Learning: A Review of the Research Literature (Paper prepared for the Alberta Ministry of Education).  
 GeoGebra (2021). GeoGebra.org. Retrieved from <https://www.geogebra.org/>  
 Gormally C, Brickman P, Hallar B, Armstrong N (2009). Effects of Inquiry-based Learning on Students' Science Literacy Skills and Confidence. *International Journal for the Scholarship of Teaching and Learning* 3(2, Article 16). <https://doi.org/10.20429/ijstl.2009.030216>  
 Harlen W (2013). Inquiry-based learning in science and mathematics. *Review of Science, Mathematics and ICT Education* 7(2):9-33.  
 Hmelo-Silver CE, Duncan RG, Chinn CA (2007). Scaffolding and achievement in problem-based and inquiry learning: A response to Kirschner, Sweller, and Clark (2006). *Educational Psychologist* 42(2):99-107.  
 Kirschner P, Sweller J, Clark R (2004). Why Unguided Learning Does Not Work: An Analysis of the Failure of Discovery Learning, Problem-Based Learning, Experiential Learning and Inquiry-Based Learning. *Educational Psychologist* 41(2).  
 Kogan M, Laursen SL (2014). Assessing Long-Term Effects of Inquiry-Based Learning: A Case Study from College Mathematics. *Innovative Higher Education* 39(3):183-199.  
 Laursen SL, Hassi ML, Hough S (2015). Implementation and outcomes of inquiry-based learning in mathematics content courses for pre-service teachers. *International Journal of Mathematical Education in Science and Technology* 47(2):256-275.  
 Laursen SL, Hassi ML, Kogan M, Weston TJ (2014). Benefits for women and men of inquiry-based learning in college mathematics: A multi-institution study. *Journal for Research in Mathematics Education* 45(4):406-418.  
 Le TT (2017). The application of Discovery learning in learning transformations. *Journal of Education of Vietnam* P 268.  
 Lê Thị Hồng Chi (2012). Vận dụng phương pháp khám phá trong dạy học môn Toán lớp 4:45-49.  
 Le VB (2007). Learning Ggeometry at The Last Classes at Under secondary School oriented discovery learning. Vinh university.  
 Madhuri GV, Kantamreddi VSSN, Prakash Goteti LNS (2012). Promoting higher order thinking skills using inquiry-based learning. *European Journal of Engineering Education* 37(2):117-123.  
 Nguyen NG (2016). Researching, designing and using e-textbooks in learning transformations on the plane according to the organization of dicoverable acts. *The Vietnam National Institute of Educational Sciences*.  
 Nguyen NG (2019). Integrating Mathematics, Informatics and Physics. The Hanoi National University Publishing House.  
 Nguyen TD (2014). Researching on The Lesson of Teacher focused on The Discovery of Mathematics of Students in Learning Mathematics at Upper Secondary School. Hanoi National University of Education.  
 Nguyen VH (2007). Applying the Discovery Learning with guiding in the Process of Teaching Mathematics at Upper Secondary School. *The Vietnam Education* P 158.



- Panasan M, Nuangchalem P (2010). Learning Outcomes of Project-Based and Inquiry-Based Learning Activities. *Journal of Social Sciences* 6(2):252-255.
- Phan TH (2013). Using the GeoGebra Software to Aid the Discovery Learning of Mathematical Theorem. *The Science Journal of Can Tho University* 27 p.
- Rooney C (2009). How am I using inquiry-based learning to improve my practice and to encourage higher order thinking among my students of mathematics? *Educational Journal of Living Theories* 5(2):99-127.
- Schoenfeld AH, Kilpatrick J (2013). A US perspective on the implementation of inquiry-based learning in mathematics. *ZDM - International Journal on Mathematics Education* 45(6):901-909.
- Spronken-Smith R Walker R (2010). Can inquiry-based learning strengthen the links between teaching and disciplinary research? *Studies in Higher Education* 35(6):723-740.
- Tran BH (2003). Learning with using Learners be Centered. *The Vietnam Information of Education Science* 96 p.
- Tran BH (2004). Learning by Discoverable Acts. *The Vietnam Information of Education Science* 102:2-6.
- Tran TTX (2011). The Discovery Learning of Genetic Dasis for Talent Students at Upper Secondary School. *Journal of Education of Vietnam*.
- Vu QK (2017). Helping pedagogical students to train problem solving competence through the exploitation of linear algebraic problems. *Journal of Education of Vietnam* 275:41-42.

*Full Length Research Paper*

# Visually supported activity suggestions to develop secondary school students' story writing skills

**Soyuçok Mehmet\* and Musa Çifci**

Department of Turkish Language Education, Faculty of Education, Usak University, Turkey.

Received 2 May 2021; Accepted 8 July 2021

There are many researches, activities and other application examples, examining the effects and importance of visuals in education. Although there are studies to develop writing skills through visuals in literature, there is no study on the development of story writing through visuals. In this study, examples of activities were developed in order to develop middle school students' story writing skills with visual aids. The study was conducted according to the qualitative research model. First, Turkey, Austria and the United Kingdom have the main story writing gains in language teaching programs and activities related to story writing skills and applications reside in the same country of which textbooks were examined. After these document reviews, the qualifications that should be found in a story were listed according to field literature data and then presented to expert opinion. Story writing activities were developed with visual support in accordance with the gains of expert opinions. The activities prepared were submitted for the approval of an examiner group consisting of a psychological counselor, a visual arts expert and three Turkish teachers, and the activities took their final form in accordance with their suggestions. As a result, validity and reliability studies were conducted and visually supported activities were produced.

**Key words:** Story writing, pre-writing activities, suggestion.

## INTRODUCTION

Writing is a complex work which has psychological, physical and emotional aspects. Writing cannot be regarded as merely transferring certain letters, words, sentences to a surface. In writing, systematic and creative thinking skills, physical competence to use writing tools, and the strength to manage and express emotions are required. In this respect, writing is a difficult task. Qualified activities are needed to be successful in writing. One of the genres that is difficult to produce is a story.

Story is one of the text types that emerges by using the writing skill, which is one of the four basic skills. Stories are the most widely encountered and most frequently used literary texts in education, due to their fictional nature and shortness. The short text type based on the narration of lived or possible events in accordance with the principles of reality is called a story (Baesler, 1997:171; Egan, 1985:399; Esenwein and Chambers, 1913:3; Rayfield, 1972:1104; Wilder, 1983:355). Stories are fictionalized by using place, time and character

\*Corresponding author. E-mail: mehmetsoyucok@gmail.com.

"This study was carried out by a doctoral thesis prepared by Mehmet Soyuçok, under the supervision of Professor Musa Çifci at Uşak University Educational Sciences Institute."

Author(s) agree that this article remain permanently open access under the terms of the [Creative Commons Attribution License 4.0 International License](https://creativecommons.org/licenses/by/4.0/)

elements and around specific events or situations (Brown, 1979:43; Carter, 1993:6; Hyland, 2015:87; Hynes, 2014:4; Roddy, 2003:4). Some skills such as thinking systematically, empathizing, learning more effectively and permanently can be acquired to the students with the genre of story (Oller, 1983:49). The story is ideal for children and even adults to understand and describe the world (Freeman et al., 2011:2; Gudmundsdottir, 1991:207; Jing and Kirkorian, 2020:1101; McKeough et al., 2005:242). In order to be a good storyteller, systematic thinking skills, physical maturity, and psychological competence to recognize the target audience are required (Filipi, 2017:279). Story writing is a skill that has mental, emotional and physical dimensions. In this respect, the story should be approached not only as a genre to be learned / taught, but as a tool that can enable students to improve as a whole.

People's relationship with visuals dates back to ancient times. Photography, painting, video, sculpture, body language, various traditional practices, etc. all of them are within the scope of visual messages. This situation directly affected the visuals. As a result of technological developments, visuals have had a wider effect and usage area than ever before (Bleed, 2005:1). The whole environment and life is full of visuals (Mika, 2012:20). Visuals play an important role in many areas such as philosophy, art, media, politics, psychology, education etc. (Khorin and Voronova, 2021:70). The indispensable position of visual elements in education is becoming more important day by day. Visuals have long been used in both face-to-face and distance education (Knupfer, 1993:2). Images are materials that enable concretization, simplification, clarity and therefore easy learning (Stokes, 2002:11). When visuals are used effectively, visual connections are established between concepts, and thus what has been learned becomes permanent (Vazquez and Chiang, 2014:10). Images; provides different learning contexts, supports learning tasks and enables what has been learned to be transferred more effectively (Gropper, 1966:37). The visuals used in education should focus on the topic and gains; it should be specific and generalizable enough to be used in similar situations (Guo et al., 2018:248).

One of the important ways where visuals are used in education is language education (Mamaliga, 2020:353). The disadvantages of working with abstract concepts in language and related culture teaching can be reduced or eliminated by the use of visuals (Kiss and Weninger, 2017:186). Visuals can help teachers in providing teaching in context, visualizing the network of concepts, summarizing the relationships between concepts, motivating students, keeping the attention alive, making the lesson fun, and facilitating teaching. Images are effective materials, especially in terms of showing effective examples in teaching speaking and listening skills. Images can also be considered as suitable

materials for various reading and writing skills.

Although stories are very important tools for education, they also cause some difficulties in "writing" (such as writing anxiety, writing discipline) in terms of writing processes; so they require a complex process that should be full of patience. For this reason, only the recommended approaches, activities and practices included in the teaching programs and textbooks may not be sufficient in teaching stories; It is necessary to use applications that will support the process by taking advantage of technological developments. For this, it would be appropriate to benefit from the support of images. When the field literature is examined, it is seen that many studies have been done on the subject such as the development of Story writing skill (Daisey and Jose-Kampfner, 2002; Jackson, 2017; Lubis, 2020; McIntyre, 2007; Meyer, 1995; Oktaviani et al., 2021; Widyastuti, 2019) and the use of visuals in education (Aisami, 2015; Galvez, 2018; Ionică, 2018; Lazard and Atkinson, 2015; Leedham, 2015; Lesnov, 2018; Lin and Li, 2018; Yarbrough, 2019; Zhang and Fiorella, 2019). These studies focus on the difficulties of teaching Story writing and also show that visuals are facilitating materials in all areas of education.

The aim of this study is to provide activity suggestions to field experts and teachers to improve the Story writing skills of middle school students. In the field literature, there are many studies on the development of Story writing skills and the use of visuals in education, but no research has been found on the effect of visuals on Story writing. This is the original aspect of the study. Story writing is very valuable, in that it enables systematic thinking, making synthesis, using the possibilities of language, reaching a certain psychological, mental and physical level, and providing the fictional power that expands the boundaries of human dreams. But it is also a skill that has difficulties. Visuals have a motivating, remarkable and facilitating effect in education. In this respect, it is thought that visuals are materials that can be used in teaching Story writing. As the teaching of Story writing is difficult, visuals are powerful teaching materials and there is no study that examines both, it is expected that the study will contribute to the field and facilitate the work of teachers.

This study, has been trying to develop an answer for the following problem question:

What kind of activities can be developed to improve students' story writing skills?

Based on this basic problem, answers were sought for the following sub-problems:

- a) What activities can be developed to improve students' writing attitudes?
- b) What activities can be developed to improve students' general writing skills?

## DOCUMENTS AND METHODS

### Model of the study

Qualitative research model is used in this study. Numerical data can not be obtained in qualitative methods, but rich and detailed data on the subject of study can be obtained (Macdonald and Headlam, 1986:35). Document analysis method was used in the research. In document analysis, printed and electronic materials are examined, interpreted, analyzed and synthesized (Bowen, 2009:27-28).

### Data collection tools and obtaining data

Document analysis was carried out in the collection of data. In this study, in order to obtain a more comprehensive list of objectives related to Story writing skills, the main language curriculum and the textbooks that are used in 2021 in terms of achievements and practices in Turkey, Austria and the UK were examined and recommended acquisition list highlighted in the field of literature were evaluated. The list was submitted for expert opinion. This list is as follows:

- 1) He/she constructs the exposition section as the introduction to the story.
- 2) Introduces the fictional atmosphere in the exposition section.
- 3) In the exposition section, he introduces the place where the story takes place.
- 4) In the exposition section introduces the time of the story.
- 5) He/she constructs the climax section in harmony with the exposition section.
- 5) Enhances the event that started in the exposition section in the climax section.
- 6) In the climax section he/she reveals the main problem.
- 7) In the climax section, he/she arouses a sense of curiosity in the reader.
- 8) He/she constructs the resolution section in harmony with the exposition and climax sections.
- 9) Concludes the event in the resolution section.
- 10) In the resolution section, he/she constructs the end of the story logically and coherently with the whole story.
- 11) In the resolution section, he/she ends the story with an impressive ending or leaves it unfinished in an intriguing way.
- 12) Decides a suitable title for story.
- 13) Decides a striking title for story.
- 14) Decides a title that covers what is told in the story.
- 15) Constructs the people in the story as types that can be encountered in daily life in accordance with the time of the story.
- 16) He/she gives the impression that the story takes place in a real time period.
- 17) He/she creates the impression that the place element in the story is a real place.
- 18) He/she gives an overlapping main ideas and supporting ideas.
- 19) Describes the main hero in the story in terms of psychological, cognitive and physical aspects.
- 20) He/she uses various senses while describing the main protagonist in the story.
- 21) He uses various senses while describing the place where the story takes place.
- 22) He uses various senses while describing the social environment in which the story takes place.
- 23) He/she deals with an event that has happened or can happen.
- 24) He/she constructs the plot in accordance with the principles of reality.
- 25) He/she organizes the plot in an interesting way.
- 26) He/she organizes the plot in an intriguing way.
- 27) Establishes cause-effect relationships between the events in the story.

With the evaluation of ten experts, the list of achievements to improve the story-writing skill was finalized. Then, the activities were submitted for the approval of an expert group consisting of a psychological counselor, a visual arts expert and three Turkish teachers, and the activities were finalized according to their suggestions. A pilot study was conducted with twenty students at seventh-grade to see the applicability and understandability of the activities. According to the results obtained from the pilot study, activities have been transformed into usable recommendations. The stories written by the students were examined by a three-person expert committee using the outcome checklist, and it was concluded that there was a qualitative difference between the stories that the students wrote stories before the activities and the stories after the activities.

### Validity and reliability

Expert opinion was sought in determining the characteristics of the story, listing the outcomes, preparing and finalizing the activities. There is an expert in visual arts, one in psychological counseling, and there are fourteen experts in Turkish education. All the experts are working depending on the Republic of Turkey Ministry of National Education and Higher Education Institutions. The gains were finalized after the expert opinions were evaluated with the Lawshe Technique.

### Limitations

The activity suggestions in this study were prepared by considering only the characteristics of the event story genre. The activity was not implemented with a large group, but a pilot study was conducted with only a small group.

### Activity suggestions

#### *Activity 1: Together, a story is born*

In Story writing, it is important to establish a cause and effect relationship between events, and to organize the plot in accordance with the principles of reality. In addition to this, the events in the story must be events that have happened or may happen. The ability to write stories suitable for these qualifications should be acquired by students within the scope of language teaching.

### Pre-event preparations

The teacher makes the following announcement at the end of the last lesson of the week before the event:

For the next lesson, I want you to read the story "Köyün Uğuru Mehmet", which I will distribute the photocopies of, at least twice and write briefly the events in the story. Storytext is distributed to students.

### Drawing attention

At the beginning of the lesson, the teacher shows the students the photos of the children playing in the school garden on the projector (Figure 1).

The teacher asks the students, "Yes, what do you see in this photo?" After receiving the answers of the students, the teacher says, "Children, what would you do for him if you had a friend who is like in this picture?" and creates a discussion environment with



**Figure 1.** Source: onedio.com (Date of access: 03/08/2020).

the question (10 minutes).

### Application

The teacher projects the following story with the projection and the text is read by the students by using the silent reading method:

#### Mehmet, The Luck of The Village

It was so hard for that he took a bus to go on the mountain road. It is a slope that made donkeys sweat in the past and it doesn't look like it will end soon. The bus is overcrowded. There are so many passengers in the bus. There isn't enough space even for the driver. He shifts the gears as the bus growls and whines.

Passengers in two rows from the back, eight of all are from the same village. They will get off the bus before arriving Çaydut, the first village after Düzce. Mehmet is among them, because they want to make fun with him. When you are with Mehmet, you can be sure that you will have fun. He'll get angry if you joke, and he'll get angry again if you don't.

Mehmet is someone who is in his thirties or forties with a wrinkled face. He has blue eyes under his thick eyebrows. Each one is like an evil eye bead... His saddlebag is between his legs... He laughs all the time. His shoes, sweat cloth are dark blue. The cap on his head is dark blue, too. Sitting right at the doorway, Mustafa:

"Mehmet Aga!" he called him, "This bus cannot go up the slope without you, and I'm so glad you're here. No matter how bad the road is, the bus will go."

Mehmet moved his mustache instead of an answering and looked back sideways. He himself knew that this was the case. It's been tried a lot. But what for, what he can you boast about? Uncle Haci, one of the administrators of the village said:

"Don't get him mad! Whoever angered Mehmet, a trouble has happened to him."

"Who is making him mad?" Mustafa muttered with a kind of fear. It's been an hour since we've reached the top of this mountain. It also started to rain. "

He leaned over the window and looked. Dark black clouds gathered in the west direction, coming fast, fast. It started to rain heavily very soon. Not rain, but hail. Each drop is the size of a walnut ... One of the glass on the left side of the bus was broken. The road itself was

submerged in water as it rained. This was not what really scared the passengers. Lightning was flashing. Then the lightning increased. The bus had fallen right under an electrified cloud. The first lightning cut the oak tree the right in half. It immediately dropped five paces away.

The women shouted and screamed. Two of them fainted. The children were crying all the time. Mustafa could not help himself and said:

"Mehmet Ağa do something to it. Please do something for God's sake!"

"Oh my Godness!" Mehmet said.

The second thunderbolt fell like a violent slap on the antenna wire that was dangling to the right of the bus. The driver and those next to him died immediately. The bus rolled over to the left. It rolled twice and stopped. Words are not enough to describe what is happening inside. After quarter of an hour, only one person held out his head from that wrecked bus.

This was Mehmet, luck of the village. He seemed to be grinning from far away, but it would be understood that he was not laughing when you came close. He had a dull and confused expression on his face. The bus was on the moat of the road. Mehmet looked around and said:

"Oh no!"

Hail was pouring down on him constantly. Mehmet took shelter under the right fender in order to protect his head and eyes. His head was covered with mud. After a while the downpour stopped. The sky was clear. The clouds left the bus and swiftly went away.

Another bus was about to cross the road in the evening. Those who saw the place were speechless with fear. They took Mehmet and left him to the first gendarmerie station. They were stunned. All those people died, but nothing happened to Mehmet. The commander listened to Mehmet. He called the District Gendarmerie Command. In an excited voice, he announced the incident to the command.

The bad news travelled fast. Everyone heard about the accident before Mehmet arrived the village. Everyone was waiting on the way. Mehmet was the only one who survived in the accident. He was sweaty and threw his sweat gland on his shoulder. When he got close, the villager stood in the middle of the road and waited for him. Everyone looked scared. His wife and his son, Tosun were on the front row. Güllü was ashamed of that. She was very happy to see that her husband was alive. Mehmet came close and said :



**Figure 2.** Source: Aile Danıřmanlıđı | Dinamik Psikolojik Danıřmanlık ve Eđitim Merkezi, date of access: 05/07/2020).

"I'm sorry for your lost." None replied him. Just a few people said "Thank you."

Mehmet walked towards his house with his wife and his son in his arms. The folks were following me. There were all seven people left on the bus. They couldn't answer "What happened, how did it happen, Mehmet?" Mehmet went to the coffee house at night to tell about the incident. When Mehmet came in the coffee house, everyone left there. Then, he went to his field partner's house. He could not find anyone at home. In short, nobody in the village wants to talk to Mehmet. His wife G ll  asked:

"Shall we move to another village?"

Mehmet was about to cry and asked:

"Why? What did I do to them? You know I'm the luck of the village". "Don't you really understand? They think that you are the reason for all this troubles".

Mehmet said:

"You are wrong. Everyone knows that I'm the luck of this village".

G ll  didn't believe him. So the husband and wife had a little argument. A week after they argued, a buffalo kicked G ll . She fell and died. Mehmet left alone in the village of thirty-five houses. He could not plow his field, he even could not get salt from the grocery store. He could not go to the coffee house. His hair and beard tangled. His son became weaker day by day. There was none to take care for him. Shortly after, a febrile illness killed him. Mehmet wanted to sell the house, the field. But he could not find someone to buy them. He left the village with a skinny donkey and a buffalo. None knew where he went or what happened to him (Mehmet SEYDA).

After the text is read, the events in the story are listed by the students under the guidance of the teacher in order of occurrence. In this step, the events are listed like this;

- 1) The bus goes ahead with difficulty on the ramp
- 2) One of the passengers makes a joke to Mehmet
- 3) Another passenger warns the other not to bother Mehmet as it could bring bad luck
- 4) It starts to rain heavily during the journey
- 5) The lightning hits bus, the bus flew into the ditch
- 6) Everyone in the bus dies except Mehmet
- 7) Another takes him to his village
- 8) The villagers impute Mehmet as being evil and exclude him.
- 9) Mehmet's wife and son die

10) Mehmet leaves the village.

After the list was prepared, the teacher asks the questions below:

- 1) Do these events happen or can happen?
- 2) Are the events interesting and intriguing?
- 3) Which events have cause and effect relationships?

First, the first two questions are answered, if the correct answer cannot be reached, instant questions guidance statements can be used. Then the third question is asked. If the question cannot be answered correctly, some questions like "Why did Mehmet leave the village?", "Why did the bus roll into a ditch?" can be asked. It is noted that the correct answer to these questions contained in the listed events. After the question are asked and answer are taken, the students asked how the event and plot in the story should be. Students are guided to give answers like; "The event in the story must be experienced or likely to be experienced, interesting and intriguing. There should be a cause and effect relationship between events and it should be ensured that the events are consistent among themselves. " If necessary, instant questions and guidance statements can be produced.

The teacher reflects a painting that shows a family sitting around a table from projection onto the blackboard. The students are told that a story will be planned in accordance with this image. Stories are started to be fictionalized as a group by the students under the guidance of the teacher (Figure 2). The questions below are asked to students;

- 1) Who should be involved in the story, what should their characteristics be?
- 2) Where should the event or events in the story take place?
- 3) How should the story begin?
- 4) How should the events in the story develop?
- 5) How should the events in the story end?
- 6) What event or events should pass? (Duration: 20 minutes)

### Writing

Students are asked to write a story based on the plan on the board. An A4 sheet of paper is distributed to each student and the students are reminded following below:

- 1) Consider the planning of the story.
- 2) You can ask the points you have in mind.
- 3) You must follow the general composition rules in your articles.
- 4) While writing, you should pay attention to spelling and punctuation.
- 5) You have 25 minutes.



**Activity 2: I'm in the library****Pre-activity preparations**

The teacher makes the following announcement at the end of the last lesson of the week before the event:

Dear children, I want to gather information about the biggest libraries in the world until our next lesson. When doing research, you can use resources such as your home encyclopedia of the internet. Also, I want you to read the story "The Broken Horse", which I will distribute to you, at least twice, until our next lesson. Story texts are distributed to students.

**Drawing attention**

Students are asked to talk briefly about the information they gathered. Volunteer students are given the right to speak, discouraged students are encouraged, but they are not forced.

**Application**

The story "Chain" is shown to students from projection:

"Chain"

My next-door neighbor, a foreign officer, had a Bulldog dog. A dog with a big head, a big neck, two females always in the square, his cheeks are hollow and drooping, his nose is sunken, upside down.

The bulldog is a dog that, for a change, has put on its original face a scary, worried, pessimistic carnival mask. Be careful, he keeps his neck upright, as if trying not to drop this makeshift black face.

Neighbor's Bulldog had hung on his face the hardest, most meticulous and ostentatious of masks I had ever seen. He looked at the world with a vengeful anarchist eye, as if it were an unnecessary, harmful, disgusting thing to be smashed and destroyed.

Twice a day, this strange figure from Senegal, created from a burly, frightening erkardif charcoal, flesh and muscles kneaded with pitch—was holding him tight by the chain, trying to vent. But with what difficulty... That dog, the big, black man, yellow. which dragged large freighters like tugboats. The beast is panting all the time, ears erect, eyes whirring, and face contorted and wrinkled with anger!..

If he gets out of the chain, no doubt, we will see that whatever comes before him, whatever comes, he will not let go of what he is holding like a vise, we will see it break and break in his hard, springy jaw. Especially not a cat or a dog, "Juju" is suffocating with greed. No barking, no howling, no groaning!

*The poor Senegalese changed the "js" he couldn't say:*

Sushi! Shut up! no matter how much he shouts, even if he hits it with the belt on his waist... Juju is all over the place, snarling, tearing, throwing, becoming unstoppable. Then, involuntarily, they pull it back into the house as if plucking it. Reaching from the balcony, a plaid and messy-haired Frankish wife takes care of herself, her deceptive skirts that smell like wet dog hair:

*Juju! Juju! Sherry. . .*

And the serenity of the street is coming back. I ask myself:

One day, what will happen when the chain breaks? What the hell

will happen?

Finally, one day, this event that I feared, expected and wondered about happened; Juju's chain remained in the hands of the nigger. The dog had sprung up like a stone from a catapult and vanished in an instant. They couldn't catch up with him, the barking that was getting farther and farther and echoing through the streets, that was it!

The "Buldok" had gone to turn the town upside down; Who knows what disasters we would hear?

However, it did not:

Two days later I saw Juju very stagnant in his chain. It means that he had returned or was found, and he had undoubtedly encountered more fierce domestic dogs, tasted his hand wiggle, became homeless, homeless, tried hunger, and left all his rage and unbridled anger.

When they took him out for air, freedom no longer seemed as appealing to him as before; The chain did not feel an unbearable burden.

In fact, later on, he began to wander around the soldier without tie; He walked unchained and well at his feet, looking at the world with the eyes of a philosopher, not with anger but thoughtfully. These eyes were now weighing the world they had begun to understand.

That old terrifying creature had become just a dog when its chain came off. Neighborhood children, who could not come near him before, surround him:

Sushi! Shut up! they were mocking. He didn't even care... Because he owed all his showmanship and heroism to the chain he thought would not break.

I believe that this chain passes through Juju's troubled eyes from time to time, like a distant, glorious memory, the dog was looking for its chain...

Refik Halit KARAY  
(Abridged and edited for the event.)

The text is analyzed with the students. In the process, students are asked the following questions:

- 1) In which part is the information about characters in the story predominantly located?
- 2) In which part is the element of time first specified in the story?
- 3) In which part in the story is the element of setting mentioned first?
- 4) In which chapter is the social context that the events in the story take place first?
- 5) What part of the story is the introduction part?

Students' answers are taken. If the answers are correct, the process continues, if not, the students are provided with the correct answer with guidance and hints. The exposition part found with the student's answers is made italic on the slide. It is said that this part is called the exposition part. The students are asked what the features of the exposition part are and they are asked to answer the question based on the questions above. The students are guided to give answers like "the events in the story start in the exposition part; some information about time, characters, setting and fictional atmosphere is given". If necessary, additional instant questions and guidance statements can be produced.

In order to reinforce what has been learned, the following visuals are shown to the students by projection, the activity sheet is distributed and the following question is asked by the students:

*Children, suppose that the story is about the picture below. Which of the pieces in the activity sheet would be the exposition part of such a story?*



Figure 3. Source: youtube.com (Date of access: 09/07/2020).

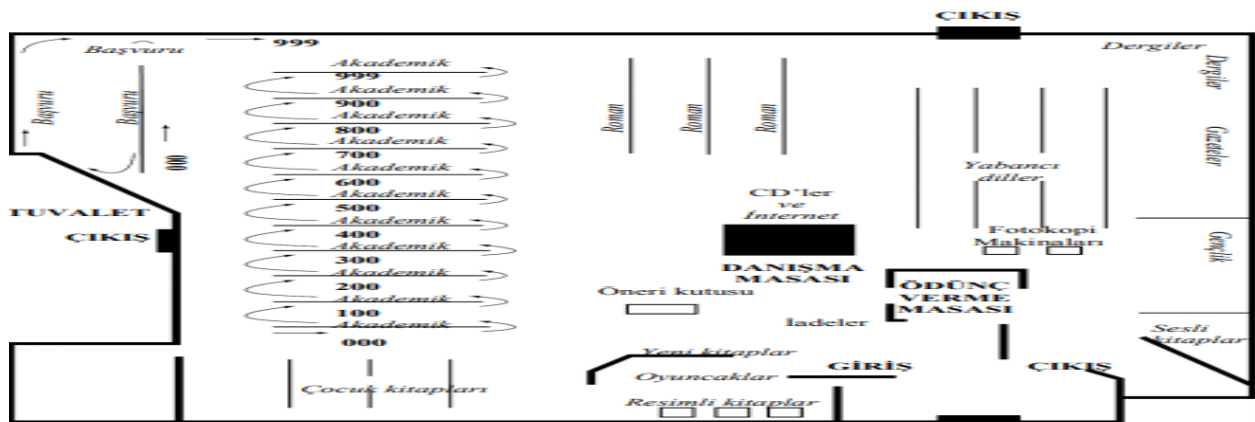

Figure 4. Source: sinavtakvim.com (Date of access: Erişim tarihi: 10/09/2020).

Dear student, There are children playing in the photo above (Figure 3) Below are the short story sections. After examining these sections and the visual, you need to tell together which piece is the exposition section and which visual this piece is compatible with.

(1) With the arrival of spring, we got into the habit of throwing ourselves into the countryside after school. Every afternoon, we took our four-legged friend with us, and we ran on the grassy field outside the village. Our favorite game was the tag. This game was a favorite of both our girlfriends and boyfriends. Our families were also comfortable because our playground was far from the road and cars.

(2) After dealing with these troubles for a long time, things finally got on the way. They continued to look to the future with hope, even after all the events that had passed through them. Their unwavering belief and confidence in life was such that would go down in history.

(3) The students, who were very affected by this incident in the classroom, decided not to mistreat their friends again. They all went out to the garden of the school to play friendly. Their eyes were bright as the teacher told their friends that negative behavior was no longer seen in their classroom.

## Writing

The library sketch is projected for students to use in writing activities (Figure 4).

Students are asked to complete the exposition part of the story, which has been given to them in blank, in accordance with the context by making use of the library sketch. They are told to benefit from this visual while fictionalizing the setting element in the story. An A4 sheet of paper is distributed to each student and they are reminded the following below:

Consider what we did in activity at the first lesson.

You can ask the points you have in mind.

You must follow the general composition rules in your articles.

While writing, you should pay attention to spelling and punctuation.

You have 25 minutes.

## The Seat Case

I thanked Ahmet and let myself go on the comfortable brown seat. As soon as I sat down, I screamed and jumped out. The teacher who was examining the library's weekly records, got angry and started shouting:

-You're so childish! If you don't want to do it, I will find another student. If you want to keep on being on duty, be calm. Don't yell like that again, I don't want uproar!

I was scolded by the teacher and also the pain of the needle was sinking into my back... My eyes were tearing with anger. When I looked up, I saw Ahmet and Ali peeking at each other and laughing quietly. When we're done, Ahmet approached me and said;

- Why did you just jump and shout? I did not say anything and left





**Figure 5.** Source: <https://www.mevkolejibasinkoy.k12.tr/> (Date of access: 15/08/2020).  
\*You draw the boundaries in your head yourself.

there quietly.

We were on duty at the library in turn once a week. Fifteen days had passed since the incident. I was on duty that day. Ahmet and Ali also forgot the incident. We started to get along very well now. As they were going to lunch, I said:

*-Why don't you come early, so we drink my fruit juice together. I finished my preparations before they came. What I call preparation is placing the two pins on the chairs... Everything was ready now. I was going to take my revenge. Even if the teacher did not see it, I would hurt them.*

Then the door opened, and I was trying hard not to laugh. But what was that! The director and our Turkish teacher were coming to check the library records during the lunch break. Before I could stop him, the director sat on one of my pinned chairs. He jumped up as soon as he sat on that pinned chair. I was not only trembling with fear but also very angry with myself. I wish I had never tried to take revenge in that way. Our teacher was stunned, blushed, spoiled and said:

- I'm very sorry. Please come and sit here. Where he pointed was my second pin seat. The same event, the same jump... This time the teacher screamed:

- Mehmeeee! he started to run after me. I jumped out of the library first and then the school door. When I got home in the evening, it didn't take me long to convince my parents that I would be more successful at another school. I didn't even pass the school for a long time!

(It was written for this event, inspired by the story of Rifat Ilgaz, Makam Cushion).

### Activity 3: Who is confident

#### Pre-activity preparations

The teacher makes the following announcement at the end of the last lesson of the week before the event:

Dear children, I want you to do a research on the concept of self-esteem for our next lesson. In your research, you can use the printed or online dictionary of the Turkish Language Institution, source books, and the internet. In addition, I want you to read the "Heritage Felt" story at least twice, which I will distribute the copies.

#### Drawing attention

Students are asked to share the information they have gained with their friends briefly. Volunteer students are given the right to speak, discouraged students are verbally encouraged but they are not forced to speak. The following cartoon, which is found by the teacher before the lesson, is shown to the students (Figure 5).

Children, as you see the yellow fish is taking shelter in an aquarium in the sea. Why is it doing that? Can you compare the two fish in this cartoon in terms of self-confidence? After the question is asked, a maximum of three students are made to answer and the answers are immediately followed by another question like "Why do you think this way?" After receiving the answers to this question, the teacher ends this part of the lesson with the following words:

Having self-confidence is a good thing when it is in moderation, and it helps people succeed. Lack of self-confidence causes people to be unable to use their potential and always stay in the background (Duration: 10 minutes).

By using the induction method and the demonstration technique, the story named "Child and Balloonist" is projected:

#### Child and Balloonist

A balloonist had been coming to the neighborhood for a while. Almost every day, and at roughly the same time, he appears from the corner with a huge cluster of balloons in his hand, "Balloons! Colorful balloons!" shouting, he would cross the street with heavy steps and turn around the other corner and disappear. The little boy eagerly awaited his arrival every day. As he watched the balloonist in amazement as if fascinated, he wondered how many balloons, which he said "wouldn't fit in our house", did not lift the man up. The balloonist was in the front, the little boy was in the back, and they were crossing the neighborhood together. Every now and then, when the balloonist paused to rest, he paused, and then continued to watch. Once again, when the balloonist stopped to rest, the little boy gathered all his courage and went to him. First, after watching the balloons closely for a while, "Uncle balloonist!" said. "You know, I've never had a balloon."

After glancing at the boy, the man said, "Do you have any money?" he asked. "It was during the holidays." exclaimed the boy. "Next feast will happen again." "Then come on the feast. I'm in no hurry, I'll wait." The boy quietly walked away from the man and from the colorful balloons. Tears were flowing from his eyes and it was as if he had no strength left to walk. He hadn't taken ten steps yet when he wanted to turn back to look at the balloons, and he

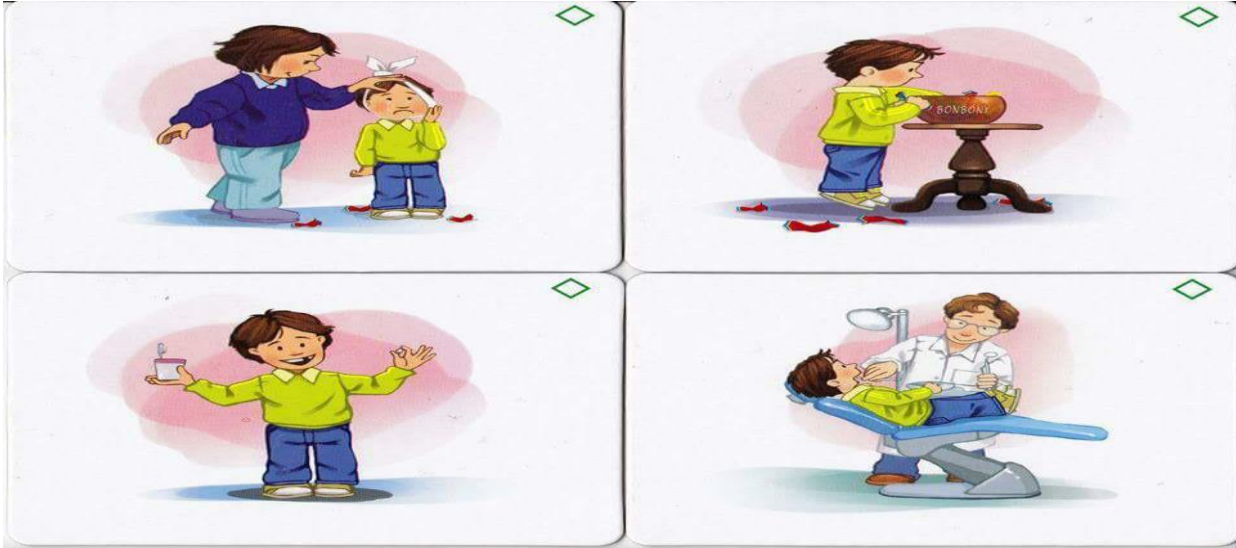

Figure 6. Source: efibarlou.blogspot.com (Date of access: 12/09/2020)

couldn't believe his eyes. The balloons somehow escaped the man's grasp and were caught in the branches of a large tree by the side of the road. The boy was stunned by the sight he saw, while looking at the balloons on the tree, the balloonist called out to him:

"Little, if you get the balloons out of the tree, I'll give you one." Hearing the balloonist's suggestion, the little boy couldn't believe his ears at first. Then he came under the tree like lightning, took off his shoes at full speed and started climbing the tree. The excitement he felt as he approached his target, step by step, didn't even feel like the thorns of the acacia tree that were stinging and hurting his legs. He finally reached the balloons. He watched them for a while, carefully shielding the balloons from the thorns of the tree, she untied the strings from the branches and handed them to the balloonist. Only one balloon had detached from the others and had risen a little higher and was stuck in the branches. If the boy tried to save him, he knew that the thorns of the tree would burst the balloon. Reluctantly, she descended from the tree, put on her shoes, and eagerly awaited the balloon that the man would give her. But the balloonist forgot his promise. After wrapping the ropes tightly around his hands, he started walking slowly towards the end of the street. The boy was surprised. "You were going to give me one of the balloons?" he asked. Man:

"Your son is in the tree, get out if you want." The boy did not have the strength to stand. He collapsed onto the curb. He turned and looked at the balloonist, who was about to disappear around the corner, and his balloons, and the crimson balloon at the top of the tree. he muttered. "Let it be! I have a balloon now, even if it stays on the tree."

Yucel Aksoy (Abridged and edited for the event.)

The text is analyzed with the students. In the process, students are asked the following questions:

- 1) In which part did the events begin to develop?
- 2) What is the main part that is intriguing?
- 3) What is the section where the main problem in the story is raised?

Student answers are received. If the answers are correct, the activity continues; If the answers are not correct, it is ensured that the correct answers are reached with guidance. The found part is

made italic. Then it is said that this part is the climax part of the story. Based on the questions above, students are asked to say what the features of the climax part are. Students are guided to give answers like "Climax is the part where the events in the story begin to develop. It contains clues about the consequences of the story and is intriguing." If necessary, additional instant questions and guidance statements can be produced.

In order to reinforce what has been learned, the following question is asked to students:

*If the images below were a story, which would be the climax part?*

The students are guided to tell that the second and the third pictures are the correct ones. If the students can't give the correct answers, additional instant questions and guidance statements can be produced (Figure 6) (Duration: 20 minutes)

### Writing

The students are asked to complete the climax part of the story, in which the exposition and resolution parts are written, but the climax part is left blank, using the writing technique to complete the text, based on the visual projected by the teacher, in accordance with the context. It is stated that they can use the image below to make predictions while completing the gap in the story (Figure 7). An A4 sheet of paper is distributed to each student and the followings are reminded are to the students:

*Consider what we did in the activity at the first lesson.*

*You can ask the points you have in mind.*

*You must follow the general composition rules in your articles.*

*While writing, you should pay attention to spelling and punctuation.*

*You have 25 minutes.*

### An Uncomfortable Bed

One October I went to spend a few weeks with some friends in a big old house in the north of France.

My friends enjoyed playing practical jokes on people. I'm not



Figure 7. Source: linkedin.com (Date of access: 15/07/2020).

interested in people who don't like playing jokes.

When I arrived, they gave me a big welcome, which made me suspicious. They fired guns, put their arms around me and made me feel important... like they were going to have some fun with me. I said to myself: "Lookout! They're getting something ready for you." During dinner everybody was laughing. Laughing too much. I thought, "These people are laughing for no good reason. They must have planned a joke... and I will be the victim of that joke. I have to be careful!"

I could smell a practical joke in the air, like a dog smells meat. But what is it? I was watchful, and I couldn't relax but I did not let a word or a movement show that I knew something was happening. I did not trust anybody... not even the servants.

The time came for sleep, and everybody in the house came to take me to my room. Why? They all said "Good-night" to me. I went into my room, shut the door, and stayed standing, without moving a single step, holding a candle in my hand.

I heard laughter and quiet talking in the corridor. I was sure they were spying on me. I looked around the walls, the furniture, the pictures, the floor. I saw nothing that made me suspicious.

An idea came into my head: "My candle could suddenly out and leave me in darkness."

Then I lit all the candles in the room. After that I looked around myself again but I didn't see anything unusual. I walked around slowly, examining every part of the room. Nothing. I looked at every object in the room, one after the other. Still nothing. I went over to the window and closed heavy curtains. I put a chair in front of the window, so that there would be nothing to worry about from outside.

I sat down in a big old chair... I didn't get into the bed.

I couldn't believe that it was daytime and the sun was shining. All the noise brought my friends hurrying into my room, and we found unhappy servant lying on the bed I had made on the floor. When he was bringing a cup of tea, he'd fallen over the mattress, spilling the hot liquid onto my face.

I had been so careful in closing the curtains and sleeping in the middle of the room... but I had made the practical joke I was trying to escape. I had been so careful in closing the curtains and sleeping in the middle of the room... But I had made the practical joke I was trying to escape. Guy de Maupassant

ENG3.W1.L5.an-uncomfortable-bed.pdf (state.tx.us)

Consider what we did in the activity at the first lesson.

You can ask the points you have in mind.

You must follow the general composition rules in your articles.

While writing, you should pay attention to spelling and punctuation.

You have 25 minutes.

#### Activity 4: What's more than a hundred

##### Pre-activity preparations

The teacher makes the following announcement at the end of the last lesson of the week before the event:

Children, how do you think a person's appearance affects our thoughts about that person? Think about that question until our next lesson. Now I will distribute the story called "The Come back" to you. I want you to read this story silently at home at least twice.

##### Drawing attention

The teacher enters the classroom even though he has a caricature and tells the students that he has read a very interesting caricature on the internet and wants to share it with them. The caricature, is shown to the students and the students are asked what their first thoughts would be if they met the person mentioned in caricature (Figure 8).

Then the teacher ends this part of the lesson with the following statements:

So, we shouldn't make firm judgments by looking at people's appearance. Because this can put us in difficult situations. The important thing is not being beautiful physically, but the beauty of the soul (Duration 10 minutes).

##### Application

The story "Heritage" is projected. The text is analyzed by the students under the guidance of the teacher.

##### "Heritage"

My uncle had put me in his place since his son Nihat died. Last year, my aunt died of grief. Now this unfortunate man sits with his servants in his palace-like mansion; I go to see him from time to time. The most moral and virtuous of people I have known in my life is my uncle. He served the state and spent his life in district governorships, governorships, and governorships of distant provinces. We, new men, cannot hear the love he has for poetry and art. The library that the garden eventually built is a secret sanctuary. Half of his day is spent here, he likes books and





**Figure 8.** Source: İçi Güzel Olanın Dışı da Güzel midir? | Ozan Keçeli (wordpress.com) (Data of access: 01.02.2021).  
\*Everyone's inner beauty reflects on your face, I wonder where mine reflects on me

caresses.

The servant who opened the door that morning said:

- The gentleman is in the library, if you want, come over there! said. I walked along, staring at the still-green flowers at the foot of the defoliated trees. The lead-lined cup dome of the library resembled an air of faceless mourning. The green-painted iron covers of the windows were open. I knocked lightly on the door, the servant thought:

- What is it, Mehmet? said.

- It's not Mehmet, it's my uncle... He opened the door.

With his white beard and thick eyebrows that made his blue tired eyes look bigger, he looked like a saint who had risen from his tomb. I kissed your hand:

- Come on, he said, let me show you a jewel.

- Here you go.

I took off my shoes. Just like entering a mosque... I wore a pair of red slippers. We sat next to the table.

"You didn't see this, you didn't see this!" she was laying the books one by one on the table. Some sofas, dates, translations, all of which had a musty smell of graves. My uncle devoted his whole life to his library, especially since he was left alone. My uncle was immersed in reading a poem. When finished reading:

- Do you know? They want to buy my library! said.

- How much do they pay?

- First, they said ten thousand liras. Then I said, "I don't sell!" When he said that, they went up to fifteen thousand, twenty thousand.

- What are you saying?

- They will even give you twenty-five thousand.

- Oh uncle, don't stop, sell it! I said. He lifted his eyes from the book he was reading. He turned to me. There was such a scolding, such a reproach in it...

- Selling my library? What do I do then?

He lowered his eyes back to the book. His face was disfigured. With a stagnant, miserable tone:

- I'm at the grave, my library is at the auction! said.

I didn't make a sound. I pretended to read the book in my hand. I don't know how long we kept quiet, it seemed too long to me. While my eyes wandered between the lines of writing, I was thinking of

twenty-five thousand liras myself. It was a small fortune. It was a fortune that would sooner or later be mine. In any case, my uncle had no heirs other than me. Who wanted the library? I would ask. The word also came into my mouth. I didn't ask. I was afraid of his clever eyes, which looked bigger, bluer, brighter under the glasses. I thought he'd understand my thinking right away. This ready legacy, which I had never thought of before, suddenly filled all my dreams. It's like my head is swollen, I'm dazed. I don't know what I'm talking about with my uncle. I left the library. We came to the hall. We sat down to eat. It was like I was in a novel. Two of my uncle:

-You have a distraction today. I remember you said you have something. While I was eating my meal at the table, my mind was constantly working and making plans. I couldn't control the ideas that were born in my head, I was silent. That's right... This poor old man was going to die soon. Twenty-five thousand liras for the library, a mansion, a vineyard, an apartment, etc. These are seventy-eight thousand liras: A fortune of one hundred thousand liras! Would I live here anymore? I would breathe in Europe and taste life with pleasure. But... If this old man tries to get married or something... But is it possible? A high-pitched demon voice inside my brain:

- Why not possible? said.

- It's not possible, it's not possible! I grit my teeth.

- No, it's possible! You'll suddenly hear tomorrow!

- That's bad...

My mind gave me an order to avoid this. The fact that the hundred thousand liras that fell at my feet flew away because of my negligence... I had to seize this wealth at any cost. Until the morning that day, I made dozens of plans to seize the wealth. I did not see any harm in any of them.

...

I didn't sleep at night! I couldn't look in the mirror so as not to see myself. Yes, all moral sentiments were a lie to me. Until the morning, I listened to the voices in my brain that gave me control:

-Don't hesitate!

- No, no, I can't.

- You will!

- I won't.



Figure 9. Source: web.watsapp.com (Date of access: 20/10/2020).

- You will miss a hundred thousand liras.
- Run away.
- You're not stupid.

No, I'm not stupid. But... I went down to my uncle early in the morning. The poor old man was drinking his milk in front of the balcony. He greeted me with a smile:

- What is that, he said, are you bothered? You turned yellow!
- I have nothing.

- Have you slept comfortably?

- I said yes. Then all of a sudden I started kissing her hands. He was surprised. I guess tears were flowing from my eyes.

- I have a request from you! I groaned. I want you to bequeath all your wealth to national institutions while you are still alive.

- But why?

- That's how I want it...

- But why?

Tell me what I was thinking at night, what plans I made to seize this hundred thousand lira as soon as possible.

I would. He would understand my true face. No, I did not have that courage. I started to tell lies. Supposedly I was young, maybe I could sell this library and get him out of the country. I wanted this important legacy to be left to the nation!

- All right, he said. Let me give my library to the nation. But my other goods...

- I don't want them either, uncle. There are so many patients. There are tears to be wiped, wounds to be healed, widows to be comforted, orphans and orphans to be comforted!

He was looking at me with deep surprise as I said it. The poor man could not understand what a low creature he was. He straightened up and embraced me. He kissed my forehead.

- You are my pride! said.

The poor old man I cheated on with my lies for the last time will also consider someone like me virtuous again! This infamous "my pride!" he will say.

Ömer Seyfettin (Abridged and edited for the event).

In the process, students are asked the following questions:

- 1) In which section do the events in the story end?
- 2) In which part is the message of the story given?
- 3) What do you think is the main part in the story that affects people?

Student answers are received. If the answers are correct, the activity continues; If the answers are not correct, it is ensured that the correct answers are reached with guidance. The found part is made italic. Then it is said that this part is the resolution part of the story. Based on the questions above, students are asked to say

what the features of the resolution part are. Students are guided to give answers like "Resolution is the part where the events in the story end. The main message is given in that part." If necessary, additional instant questions and guidance statements can be produced. In addition, the students are asked to say which of the following emojis are compatible with the exposition, climax and resolution parts of this story (Figure 9) (Duration: 20 minutes):

### Writing

As the last step of the demonstration technique, students are asked to complete the resolution part of the story called "TheComeback", in which the exposition and climax parts are given and the resolution part is left blank, in accordance with the emotion in the emoji at the end of the story. It is said that these images mean love, affection and closeness, in case of confusion in terms.

An A4 sheet of paper is distributed to each student and the followings are reminded to the students:

*Consider what we did in the activity at the first lesson.*

*You can ask the points you have in mind.*

*You must follow the general composition rules in your articles.*

*While writing, you should pay attention to spelling and punctuation.*

*You have 25 minutes.*

### "Dentist"

It is said that those who do not suffer do not know: There are very few people who do not suffer, what a terrible thing this toothache is. If other parts of the body get sick, the head will still manage, but if the head and brain get sick, what should the body do?

Once, our lady's teeth were abscessed; We were in a village covered with snow on all four sides. There are no doctors, no barbers, and the roads are not open so that you can go to the province... For a week we wandered around each other like lions in a cage; The woman wept shrilly. Whatever the case... Now, thank God, we are in a place that has a doctor. If there are no snow storms in winter, the roads will take the man to the province. But there is no dentist here either. The doctor gives medicine, but when it gets tight, it doesn't interfere, let's spend a car and move to the province. So he told us to take our lives. One day, good news spread: The brother of the agricultural officer was a journeyman with a dentist in Adana. He wanted to come here by playing some team tricks, but he was hesitant because he did not have a license; What would the judge, the district governor or something say, he

should have asked. The ground was felt; they are already complaining about the same problem; "We don't officially know about it." they said. Finally the dentist showed up one day.

Their teams were brilliant. I scored something like this. He knows quite a few things. On the practical side, there is nothing to say. Even those who are not hard of teeth stop by just in case and start the repair phase. Fillings, veneers, bridges, even dentures... The villagers, especially... The poor ones are so happy that they are so happy to drive a stake into the ground and tie their tooth to it with rope, to tie the rope to the door and throw a tooth with a kick; they even got rid of it by tying it to a mauser bullet and flying it. They all breathed a sigh of relief.

One day, Murtaza Bey also had a toothache, and he went to the dentist, whose praise he heard by ear. The dentist pulled out a painful rotten tooth, filled one, and for the other cavities: "These are open, they form abscesses, they swell, let's take timely measures." said. Our Ağa found the activity of that day sufficient and left. Two days later, I saw Murtaza Bey in Çopur İlyas's coffee house: One hundred eyes were swollen, his head was wrapped around his neck. His face turned crimson.

- Get well soon, Mr. Murtaza... No, I hope?

It must have been roaring anyway, and it exploded at my word:

- Is he coming to the country without a rope or is he coming with no good? Will they scam people? Have you ever watched? They ignore the district governor, the judge will squint... Fortunately, they didn't cut off our heads and give them to us.

- My dear, they didn't take you there by force... If you don't like it, you shouldn't have gone.

- What if someone who doesn't know the law and book says that... How do you say that to a man like me? Don't you know what they do to a dentist without a diploma or license? I will complain everywhere.

There is an informal, illegal, unlicensed business. I was very sorry. We will be without a dentist and a lot of people will be in trouble. I saw Blind Haji in the cafe, I told him my problem. Haji immediately found the solution:

- They should give Murtaza Bey's money back. Let them do their teeth. Wait and see!

This idea occurred to me as well, so I immediately went to the dentist.

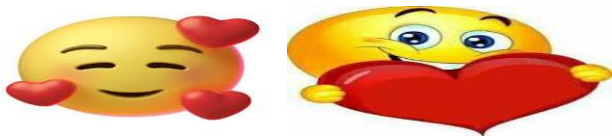

Muhtar Körükçü (Abridged and edited for the event).

## RESULTS AND DISCUSSION

In the study conducted by Yeh (2010), with eight teacher candidates were studied. In this research, it was seen that visuals could be understood and used without training. These findings coincide with the starting point of the research. In this study, it was assumed that the visuals were easy to understand, they also supported learning and the students would be able to understand the visuals without any training.

In the research conducted by Jain (2018), it was determined that visuals affected the consumers' perceptions and direct consumer behavior. This study also supports the idea that visuals will guide student

behaviour. It is thought that with the activities carried out within the scope of the study, students' story writing skills and their attitudes towards writing will be improved.

In the study conducted by Rowsell et al. (2012), it was mentioned that visuals offered concrete details and were directive to discover meanings, and it was stated that visuals should be used more in accordance with developing possibilities. It is stated in this study that visuals should be more intensively used in the classroom and visuals can be used in the teaching of abstract subjects.

The results of the study by Susilawati (2017) of this study overlap with each other. Susilawati used comics in her study and it was determined that this improved her story writing skills. This study is based on the same assumption.

In the study conducted by Megawati and Alkadrie (2017), it was revealed that teaching writing using photographs provides more effective results. In this research, it has been seen that the ability to write a story can be improved through visuals such as photographs.

The findings are in line with the findings of the study by Noreewec and Margana (2018). In both studies, videos were used and it was concluded that these images would improve students' writing skills.

In the study conducted by Sinaga (2018), it was seen that the use of animation films in teaching narrative writing increased learning success. In this study, visual materials were used to improve story writing skills.

Many international studies have shown that it is really difficult to teach the story writing skill and that some extra applications are needed in addition to the curriculum (Ahmad et al., 2020; Alkaaf and Al-Bulushi, 2017; Lane et al., 2010; Wilson, 2019). In this study, it is also found out that the activities and strategies used in the teaching programs and textbooks for the story-writing skill are insufficient; new approaches and activities based on these approaches are needed to improve the story writing skills. It can be said that the activity suggestions are in accordance with the general approach and point of view in the literature.

## Conclusion

Although there are many studies in the literature on story-writing skill and the use of visuals in education, there is no study that deals with both of these subjects. For this reason, activities which aim to improve the story writing skill through visuals are prepared. The activities consist of preparation for the lesson, drawing attention, application and writing sections. Each stage of the activities is planned in a way that enables active participation of students. In the pilot activities, it was observed that the activities could be understood by the students and completed on time. It has been observed that student motivation is higher compared to other activities in pilot activities. Since motivation is a

prerequisite for success, it is thought that activities will affect student success. With this study, it has been revealed that visually supported activities will be beneficial in terms of teaching and developing the skill of writing an event story. In the study, tools that are frequently encountered in daily life such as cartoons, silent films, documentaries, paintings, photographs are included, and thus, it has tried to draw attention to the fact that writing a story is also a part of daily life.

To date, there is no study that directly addresses this issue. It is hoped that this study will contribute to the field by providing teachers with new opportunities in their classroom practices and gaining new perspectives through the activities prepared.

## Recommendations

Within the scope of the study, the following recommendations are made for researchers:

- 1) The activity set can be applied with a large number of students
- 2) The activity set can be used by adapting to the case story.
- 3) Similar studies can be performed for other text types.
- 4) Similar studies can be performed with advanced visual techniques.

## CONFLICT OF INTERESTS<sup>1</sup>

The authors have not declared any conflict of interests.

## REFERENCES

- Ahmad A, Samiullah M, Ahmed G(2020). Development of Story Writing Skills through Communicative Approach at Secondary Level in Pakistan. *Global Regional Review* 1:143-150.
- Aisami RS (2015). Learning styles and visual literacy for learning and performance. *Procedia-Social and Behavioral Sciences* 176:538-545.
- Alkaaf F, Al-Bulushi A (2017). Tell and write, the effect of storytelling strategy for developing story writing skills among grade seven learners. *Open Journal of Modern Linguistics* 7(2):119-141.
- Baessler EJ (1997). Persuasive effects of story and statistical evidence. *Argumentation and Advocacy* 33(4): 170-175.
- Bleed R (2005). Visual literacy in higher education. *Educause Learning Initiative* 1(1):1-11.
- Bowen GA (2009). Document analysis as a qualitative research method. *Qualitative Research Journal* 9(2):27-40.
- Brown GH (1979). Children's sense of story and their reading. *English in Australia* 1(47):43-50.
- Carter K (1993). The place of story in the study of teaching and teacher education. *Educational Researcher* 22(1):5-18.
- Daisey P, Jose-Kampfner C (2002). The power of story to expand possible selves for Latina middle school students. *Journal of Adolescent and Adult Literacy* 45(7):578-587.
- Egan K (1985). Teaching as story-telling: a non-mechanistic approach to planning teaching. *Journal of Curriculum Studies* 17(4):397-406.
- Esenwein JB, Chambers MD (1913). *The Art of Story-writing*. Springfield: Home Correspondence School.
- Filipi A (2017). The emergence of story-telling. In *Children's Knowledge-in-Interaction* pp. 279-295. Singapore: Springer.
- Freeman NK, Feeney, Moravcik E (2011). Enjoying a good story: Why we use children's literature when teaching adults. *Early Childhood Education Journal* 39(1): 1-5.
- Galvez R (2018). Effectiveness of Animated Visuals for the Teaching of Chemical Bonding in Junior High School Chemistry. *International Journal of Education and Research* 6(1):119-128.
- Gropper GL (1966). Learning from visuals: Some behavioral considerations. *AV Communication Review* 14(1):37-69.
- Gudmundsdottir S (1991). Story-maker, story-teller: narrative structures in curriculum. *Journal of Curriculum Studies* 23(3):207-218.
- Guo D, Wright KL, McTigue EM (2018). A content analysis of visuals in elementary school textbooks. *The Elementary School Journal* 119(2):244-269.
- Hyland K (2015). *Teaching and Researching Writing*. Edinburgh: Pearson.
- Hynes J (2014). *Writing Great Fiction*. Virginia: The Teaching Company.
- Ionică L (2018). Foreign Language Teaching through Visuals. *Studii și cercetări filologice. Seria Limbi Străine Aplicate* (17) 86-89.
- Jackson D (2017). Can games help creative writing students to collaborate on story-writing tasks? *International Journal of Game-Based Learning (IJGBL)* 7(3):38-50.
- Jain P (2018). Visual persuasion-a creative aspect in communication. *International Journal of Humanities and Social Sciences* 7(3):5-12.
- Jing M, Kirkorian HL (2020). Teaching With Televised Stories: A Story-Focused Narrative Preview Supports Learning in Young Children. *Child development* 91(5):1101-1118.
- Khorin A, Voronova E (2021). The Role of Visuals in the Communication Process. *Filosofija. Sociologija* 32(1):69-75.
- Kiss T, Weninger C (2017). Cultural learning in the EFL classroom: The role of visuals. *Elt Journal* 71(2):186-196.
- Knupfer NN (1993). Enhancing local and distance education with computer-produced visuals. Available at ED393415.pdf
- Lane KL, Graham S, Harris KR, Little MA, Sandmel K, Brindle M (2010). Story writing: The effects of self-regulated strategy development for second-grade students with writing and behavioral difficulties. *The Journal of Special Education* 44(2):107-128.
- Lazard A, Atkinson L (2015). Putting environmental infographics center stage: The role of visuals at the elaboration likelihood model's critical point of persuasion. *Science Communication* 37(1):6-33.
- Leedham M (2015). Chinese students' writing in English: Using visuals and lists. *English Teaching in China (ETiC)* 6:16-20.
- Lesnov RO (2018). Content-rich versus content-deficient video-based visuals in L2 academic listening tests: pilot study. *International Journal of Computer-Assisted Language Learning and Teaching (IJCALLT)* 8(1):15-30.
- Lin L, Li M (2018). Optimizing learning from animation: Examining the impact of biofeedback. *Learning and Instruction* 55:32-40.
- Lubis RI (2020). The effect of story mapping strategy on students'achievement in writing narrative text. *jurnal liner (Language Intelligence and Educational Research)* 3(2):102-112.
- Macdonald S, Headlam N (1986). *Research Methods Handbook*. Manchester: CLES.
- Mamaliga A (2020). The role of visuals aids in teaching grammar. *Materialele Conferinței Republicane a Cadrelor Didactice* 3:353-356.
- McIntyre E (2007). Story discussion in the primary grades: Balancing authenticity and explicit teaching. *The Reading Teacher* 60(7):610-620.
- McKeough A, Davis L, Forgeron N, Marini A, Fung T (2005). Improving story complexity and cohesion: A developmental approach to teaching story composition. *Narrative Inquiry* 15(2):241-266.
- Megawati M, Alkadrie S (2017). The Effectiveness of Using Photograph in Teaching Writing. *Journal of Education, Teaching and Learning* 2(2):138-146.
- Meyer RJ (1995). Stories to teach and teaching to story: The use of narrative in learning to teach. *Language arts* 72(4):276-286.

<sup>1</sup>This study was carried out by a doctoral thesis prepared by Mehmet Soyucok, under the supervision of Professor Musa Çifci at Uşak University Educational Sciences Institute



- Mika K (2012). Using Visuals to Enhance Student Learning. *The Law Teacher* 18(2):20-28.
- Noreewec A, Margana MA (2018). The effectiveness of the utilization of videos as supplementary teaching material in genre-based approach to teach writing skill. Available at <https://sgm.gr/mKvOx>
- Oktaviani IC, Mustika I, Sudrajat RT (2021). The application of the cooperative story type cooperative method in learning write short stories. *JLER (Journal of Language Education Research)* 4(1):36-45.
- Oller Jr JW (1983). Story writing principles and ESL teaching. *TESOL Quarterly* 17(1):39-53.
- Rayfield JR (1972). What is a story?. *American Anthropologist* 74(5):1085-1106.
- Roddy L (2003). *How to Write a Story*. Atascadero: Institute for Excellence in Writing.
- Rowell J, McLean C, Hamilton M (2012). Visual literacy as a classroom approach. *Journal of Adolescent and Adult Literacy* 55(5):444-447.
- Sinaga YP (2018). The Effectiveness of Using Animated Film in Teaching Writing Narrative Text. Available at <http://repository.uhn.ac.id/handle/123456789/1775>
- Stokes S (2002). Visual literacy in teaching and learning: A literature perspective. *Electronic Journal for the integration of Technology in Education* 1(1):10-19.
- Susilawati F (2017). Dijital çizgi roman yoluyla öyküleyici metin yazmayı öğretmek. *Journal of English and Education* 5(2):103-111.
- Vazquez JJ, Chiang EP (2014). A picture is worth a thousand words (at least): The effective use of visuals in the economics classroom. *International Review of Economics Education* (17):109-119.
- Widyastuti A (2019). The use of storytelling method to improve students' ability in writing stories and teacher's ability in telling stories. *Hortatori: Jurnal Pendidikan Bahasa dan Sastra Indonesia* 3(2):133-146.
- Wilder AN (1983). Story and story-world. *Union Seminary Review* 37(4):353-364.
- Wilson D (2019). Exploring a teacher's facilitation of a collaborative story writing unit using Google Docs in a culturally and linguistically diverse high school English class (Doctoral dissertation). University of Victoria, Victoria.
- Yarbrough JR (2019). Infographics: in support of online visual learning. *Academy of Educational Leadership Journal* 23(2):1-15.
- Yeh HT (2010). Towards evidence of visual literacy: Assessing pre-service teachers' perceptions of instructional visuals. *Journal of Visual Literacy* 29(2):183-197.
- Zhang Q, Fiorella L (2019). Role of generated and provided visuals in supporting learning from scientific text. *Contemporary Educational Psychology* 59:1-14.

## VISUAL SOURCES

- Figure 1. 10 Maddede Bir Entelin Toplumda Var Olma Çilesi - onedio.com
- Figure 2. Aile Danışmanlığı | Dinamik Psikolojik Danışmanlık ve Eğitim Merkezi
- Figure 3. EN GÜZEL ÇOCUK ŞİİRLERİ DİNLE - YouTube
- Figure 4. PISA'da nasıl sorular soruluyor? | Bilsem Sınav (sinavtakvim.com)
- Figure 5. İLKOKUL-REHBERLİK-BÜLTENİ.pdf (mevkolejbasinkoy.k12.tr)
- Figure 6. "Παίζω και μαθαίνω στην Ειδική Αγωγή" efibarlou.blogspot.gr: Νοεμβρίου 2018
- Figure 7. In a lather over gender bias in ads (linkedin.com)
- Figure 8. İçü Güzel Olanın Dışı da Güzel midir? | Ozan Keçeli (wordpress.com)
- Figure 9. WhatsApp



*Review*

# The theoretical analysis of ethical leadership lapses: A disturbing concern about school leadership in Botswana

Nkobi Owen Pansiri<sup>1</sup>, Chikezie Ignatius Ugwu<sup>2\*</sup> and Wazha Bickie Maundeni<sup>3</sup>

<sup>1</sup>Department of Primary Education, Faculty of Education, University of Botswana, Botswana.

<sup>2</sup>Department of Educational Foundations, Faculty of Education, University of Botswana, Botswana.

<sup>3</sup>Department of Languages and Social Sciences, Faculty of Education, University of Botswana, Botswana.

Received 10 July, 2021; Accepted 23 August, 2021

**A school is the only place with a formal and legitimate mandate of duty of care for the learner. Schools are expected to be nurturing environments free of abuse, exploitation, violence, bullying, humiliation, discrimination, harassment, negligence, cultural stereotypes, emotional distress, socio-economic marginalisation and moral prejudices. Some concerns about governance and ethical leadership in schools are therefore inevitable. Drawing from the Eurocentric and Afrocentric theoretical perspectives, this article discusses lapses of ethical leadership practices in Botswana with a deliberate focus on school leadership systems. Secondary data is drawn from the media and government reported cases on the growing systemic social decadence. It is argued that unethical conduct in the education system in the country is heightened by lack of an Africanized ethical code of conduct for educators and double-dipping by the public officers. The article recommends an indigenized research approach on ethical leadership and governance.**

**Key words:** Afrocentrism, eurocentrism, ethical leadership, code of conduct, good governance, indigenized research, Ubuntu/Botho.

## INTRODUCTION

Until 2019, Botswana, a sovereign state in Southern Africa which is a former British colony that obtained self-rule in 1966, used to be described as the world's leading record of a shining example of democracy in Africa. The perceptions about the success story of this democracy attributed this world rating to good governance. The 2019 democracy and governance perception index reduce Botswana from this perception record to where only 58% of the citizenry felt that the country was going in the right direction. This drastic U-turn in perceptions towards

socio-economic and political development motivates this article to reflect on governance practices in all sectors of the country's economy. It explores mainly 'ethical leadership' challenge as a critical component of governance in the socio-economic development of Botswana, and school leadership practices. Even then, the discussion limits itself to ethical leadership as experienced in school governance. It is mainly a desk-based approach, informed by current official and media reports and associated literature about Botswana.

\*Corresponding author. E-mail: [chike\\_3@yahoo.com](mailto:chike_3@yahoo.com).

Concerns about governance and ethical leadership in education and in schools are inevitable, given that the school is the only place with a formal and legitimate mandate of duty of care for the delicate growing and developing person - the learner. The school is, therefore, a critical place in the process of human capital development in any society. In all its functionalities, a school is required to ensure that all its clientele are placed in an operationally nurturing environment that is free of risks against and from exposure to abuse, exploitation, violence, bullying, humiliation, discrimination, harassment, negligence, cultural stereotypes, emotional distress, socio-economic marginalisation and moral prejudices. Despite this being a legitimate social expectation of the functionality of a school, on the contrary the media is littered with stories of the existence of moral decay in the standards of ethical leadership and governance in schools. Like in many other sectors of the economy, schools find themselves under dictatorial leadership (Jespersion, 1992), leadership with endemic corruption (Klitgaard, 1988), dysfunctional leadership with unethical concessions, leadership that promotes bad followership (Chigbu, 2011) and leadership that has become part of the evil socio-political and economic cohesion (Good, 2009; Jawondo, 2011).

### **Objectives of the discussion**

This discussion, therefore, seeks to critically review ethical leadership lapses in the Botswana context with specific and deliberate focus on school leadership systems. The objectives are to:

- 1) Conceptualize ethical leadership, governance and good governance;
- 2) Position Botswana's development in the theoretical perspectives of ethical leadership practices;
- 3) Identify and explore cases of ethical leadership lapses in Botswana schools;
- 4) Motivate further research on ethical leadership in schools.

### **LITERATURE ON GOVERNANCE AND ETHICAL LEADERSHIP**

One of the core characteristics shared by successful organizations is their ability to recognize effective leaders and harness them in order to maximize results (Miller, 2014). In other words, no organization can grow to its full potential without effective leadership. A major differentiating factor between an effective and ineffective leader is the nature and quality of governance. This is so because governance plays a very important role in fostering shared aims, collective commitment and accountability, and in providing strategic direction for leaders (Lord et al., 2009). The concept of governance and the practices of good governance need to be

understood and appreciated. Understanding governance is dependent on the angle from which one approaches it. It can be explored from a functional perspective where one tries to understand it as processes and procedures in leadership and management. It can be approached from characterizing behavior of those in leadership and management against results. This discussion tries to adopt a more neutral position so that both angles are accommodated to strengthen the conceptualization of governance in terms of general functional conceptualization and regarding its processes and practices.

In terms of functionality, governance, according to Fukuyama (2013), is the ability to make and enforce rules and to deliver services, regardless of whether the process is democratic or not. This definition opens doors for dictatorship, the processes to which are enforcement of practices that do not follow democratic procedures. Following the same line of thinking, the United Nations Economic and Social Commission for Asia and the Pacific (UNESCAP) (n. d.) defines governance as the work of making and implementing (or not implementing) decisions. It generally deals with the procedures and processes put in place to enhance accountability, management and direction of an organization. One key term that is inherent in this functional definition of governance is 'decision making'. The ability of a leader to make the right decisions is what differentiates good governance from bad governance. The African Development Bank (as cited in Gaisselquist, 2012) defines good governance as one that combats corruption and promotes enabling and judicial framework, accountability, participation and transparency. Following the same line of thinking, UNESCAP (n. d.) defines good governance as one that is transparent, inclusive, equitable, efficient, responsive, effective, consensus oriented, participatory and accountable. So, good governance is characterized by desire to achieve zero tolerance for corruption, and improved open participation of all the stakeholders in decision-making.

With regard to processes and practices, a critical vehicle for fostering good governance and for achieving organizational goals is a leadership style grounded in ethical norms and practices (Okagbue, 2012) that introduces morality as a core leadership (Zaleha and Rashidah, 2014). The type of leadership that is cognizant of moral standards is characterized as ethical leadership. Ethical leadership is a human behaviour respected and valued for being character building focused, ethically aware, team interest orientated, truthful, unselfish, civil minded and trustworthy (Sharmini et al., 2018). From a similar school of thought, Komal and Sheher (2015) perceive ethical leadership as one that is characterized by integrity, fairness, role clarification, power sharing, concern for others and concern for sustainability. However, following another line of thinking, Shacklock and Lewis (2006) view ethical leadership as the creation

and fulfillment of opportunities that are worthwhile using means that are deemed honourable. From the foregoing and as indicated by several studies (Eranil and Ozbilen, 2017; Okagbue, 2012; Sharmini et al., 2018), it is imminent that ethical leadership can serve as a tool for effective leadership, given the view that it promotes good governance. Ethical leadership would be rated above others as it is based on the individual character that is led by example and always cares about other's wellbeing. It contains powerful intrinsic behaviour traits which are rare to be displayed by most leaders of this era. For instance, truthfulness, unselfishness and trustworthiness are hardly displayed by most leaders as those in leadership positions have the tendency of believing that they are there because of competency and infallibility, and are therefore, indifferent to the contributions for the success of the organization. For purposes of the focus of this discussion, it is worth conceptualizing ethical leadership concerns in schools.

### **ETHICAL LEADERSHIP CONCERNS IN SCHOOLS**

A school is a critical centre of human socialization. Its unique legitimate responsibility is to develop and/or transmit worth-while knowledge of morality and skills of ethical conduct to learners, who are potentially true miracles of life. The moral knowledge and skills of ethical standards, such as sex education, drug awareness and conflict resolution, need to be transmitted within the confines of set humane parameters influenced by emerging mores, diverse morals and conflicting values (Saldana, 2013). However, with rising incidences and cases of immoralities in the human society, ethics need to be taken very seriously in schools. This is fundamentally desirable because teachers and school leaders do not only face ethical problems, but they are also responsible for whether the next generations will be educated properly to be moral people or not (Mukadder et al., 2017). The school leader is, therefore, a moral agent of socialization and is expected to play a major role in establishing and sustaining an ethical and moral climate in the school (Sabre et al., 2015). There is a need for school leaders to discharge their leadership duties in an ethical manner. It is a position that education leadership policy statements of many countries need to highlight unambiguously and conspicuously. However, the ability of school leaders to discharge their duties in an ethical manner is continuing to be a major source of concern, especially in the face of rising incidents and cases of unethical conduct in schools. This section, therefore, examines the concerns of ethical leadership in the international, regional and Botswana context.

#### **International perspective**

This sub-section assumes that the United States (US),

Australia and England are among the leading developed economies which have policies and systems of ethical standards that emerging nation states can benchmark from. It is assumed that these countries have advanced education policies which anchored on values and the importance of ethics in the education systems. For example, Utah, a state in the United States (US) in strand five (5) of the "Utah State Standards for Educational Leadership" argues that leaders in the education sector must modify ethical leadership and promote professional attributes of integrity, fairness, transparency, and trust (Utah Educational Leadership Toolkit 5, 2019). In Australia, one popular policy for ethical leadership is the code of ethics drafted in 2005 by Victorian Institute of Teaching for schools in Victoria State. This policy instrument forms a basis of code of conduct and it is not a disciplinary tool, but a tool for guidance in the decision-making process (Forster, 2012). Unlike the US and Australia, England has a single code of conduct for the whole nation. The ethical principles reflected in the code include honesty, truth, transparency, accountability, fairness, democratic governance, and personal and systems improvement. However, compared to the codes of conduct for teachers in other countries with similar systems (for example, Ireland) and other parts of the United Kingdom (for example, Scotland), the codes of conduct in England lay less emphasis on internal ethical values of teachers and more on observing the rules of the school and statutory regulation (Maria and Valts, 2017).

Despite the well-crafted policy statements in these advanced countries, cases of unethical behaviour have continued to rise daily. A study conducted by Ethics Resource Center in the United States of America in 2008 reveals that at least 57 percent of government employees reported that they witnessed violations of policies, laws or ethical standards in their place of work in a period of 12-months, and that a third of these violations were not reported (Cheteni and Shindika, 2017). These violations were in form of sexual harassment, unfair treatment of workers, misquoting work hours and even violations of privacy. A recent report by Pagones (2020) on how a teacher poisoned 25 kindergartners out of revenge shows that globally, the question of ethics has remained far from being brushed away. Apart from lack of clear implementation framework, other gaps inherent in ethical leadership policies in these developed countries are lack of ownership, rules without aspirational value statement and creating policies that are not embedded in professional culture.

#### **African perspective**

African nation-states are a product of the colonial craft. Their development policies and systems are one way or the other aligned to the colonial culture of development. This is more so because the emergence of globalization,

neo-liberalism and market economy as a Eurocentric economic model of development has disrupted the Afrocentric social development approach of Ubuntu or Botho in Setswana language (Pansiri et al., 2021). Pansiri et al. (2021:173) argue that the Ubuntu theory is a “humane approach known for ethical social practice, collective communal leadership and good governance”. Since the adoption of the Eurocentrism and its related education systems and policies, ethical leadership is also a major concern in African schools. Studies of Africa have frequently shown the prevalence of weak and failed/failing states (Bah, 2012). As a consequence, most of such countries experience huge corruption and misappropriation of public funds (Atuobi, 2007; Ojo, 2018). Failing state governance systems were experienced in countries such as Eritrea, Malawi, Cameroon, Uganda and Sierra Leone when central governments became weak, and governments failed to raise revenue. Corruption and criminality became rampant and sharp economic decline was felt. As for the failed states such as Somalia, Zimbabwe, Kenya and Nigeria, there was breakdown in democratic dispensations, allowing African continent to be dominated by brutal self-serving dictators who abused power, sometimes preferring to use violence to compensate for lack of popular support (Cheeseman, 2015). These failed states had government that lost control over their sovereignty, lost legitimacy to perform functions of governance that include management of public service, lost integrity to interact with other states as full members of the regional or international community. However, both failing and failed states fall into a category of failing democracies. The failing democracies can be attributed partly to unethical leadership within governance structures. Of course, due to the dictates of Eurocentrism which is regulated by globalization, neo-liberalism and market and money economy (Pansiri et al., 2021), there are also external forces that disturbed internal workings of organizational systems such as those witnessed due to Post September 2011 events in Iraq, Pakistan and Afghanistan (Brinkerhoff and Brinkerhoff, 2002), where the Western powers caused chaos in these countries under the pretext of fighting Islamic insurgents. Once state failure occurs, inevitably all state functionaries and institutions including schools are affected.

Just like in more advanced countries, different and less advanced countries in the Africa region have well formulated policies for ethical leadership in schools to reduce negative impact of failing democracies. One popular policy is the School of Management and Leadership programme rolled out by the Department of Education in South Africa (SA) in 2007 aimed at creating a school leadership that is dynamic, ethical and competent to the ever changing educational climate (Kgomotlokoa et al., 2016). However, a report by Naidoo (2015) reveals that teachers, principals, union members and departmental officials in SA have all been cited in

different reports and research studies regarding unethical conduct in the Department of Education. This is further confirmed in a report by Head (2017) on how a teacher in Durban, a region in SA was suspended after his intimate relationship with a 14-year-old Grade 9 pupil went public. In Nigeria, Chapter four of the Teachers Registration Council of Nigeria (TRCN) codes of conduct states that academic/administrative leaders should act as sources of inspiration and motivation, and they should exhibit charisma, foresight, justice, empathy, self-respect, selflessness, honesty, consistency and moral-uprightness in their services (TRCN Code of Conduct, 2013). Despite this, concerns on ethical leadership in schools in the country have continued to rise. This is exacerbated by different reports in the media. For example, a report by Oramadike (2020) reveals the involvement of about forty-one (41) teachers in examination malpractice in a state in Nigeria. These worrying reports from Africa’s powerful economies (South Africa and Nigeria), show that ethical leadership policies are far from being implemented in the continent. The policies are further marred by lack of ownership since education leaders view these policies as rules and regulation that are to be obeyed rather than seeing them as the right thing to do.

### **Botswana perspective**

At independence in 1966, Botswana adopted a development theory guided by four national principles namely democracy, unity, development and self-reliance. Along the Eurocentric economic theoretical model of development (Pansiri et al., 2021), Botswana gradually expanded liberal economic development model that allows the growth of the private sector. The concept of private partnership emerged and grew rapidly. Pansiri et al. (2021:182) argue that the Eurocentrism which is “driven by ... [stiff] competitive, harsh and rapid technological growth and associated markets and industry economy poses a threat to Ubuntu, the Afrocentric theory of social development”. Botswana, like any African nation-state, aggressively and inevitably transformed from the egalitarian social development practices cultured by communal values of Ubuntu to competitive formation of the money and market economy.

With rapid population growth and related rising cases of youth unemployment, Botswana introduced and encouraged entrepreneurship. The market and money-economy funding schemes such as National Development Bank (NDP) and Financial Assistance Policy (FAP) were introduced to facilitate employment creation and entrepreneurship with the desire to fulfill economic and political theory of citizen economic empowerment. To provide regulatory oversight, and ensure compliance to ethical conduct, Botswana set up a Directorate of Corruption and Economic Crime (DCEC). It is worth noting here that in 2008, Botswana introduced

“Botho” or “Ubuntu” as one of the principles of development. This was in realization that the known social codes of development needed to be embraced in new practices of entrepreneurial economic development. The principle was also introduced at a time when the country experienced signs and symptoms of defective leadership and elements of moral decay in public service. Under the pressure of trade unions which was leaning more towards the opposition political formations and in fear of change of government, the country through Public Service Management Directive No. 8 of 2014 Review of Condition of Service for Public Service decided to “allow Public Service employees to engage in private business...” (Republic of Botswana, 2014:1). The related implementation guidelines were issued to regulate public officers’ participation in private business, and performances in paid work outside official employment during or outside working hours. Inevitably, this encouraged public officers to have interest in becoming entrepreneurs, a trap quite attractive to conflict of interest and unethical practices, let alone corruption. The implementation and implications of this directive on ethical conduct of the Public Service, governance and ethical leadership are yet to be critically explored. This point will, however, be reflected later in this discussion.

The country has gone through many programmes, extended the spirit of democratic governance that exists at the macro-political level ethical leadership in the country to schools. Efforts to achieve this are being made partly through the School Management Manual which encourages school leadership to promote good working relationships as well as to establish high morale among the staff (Moswela, 2007). Programmes such as the School Development Plan (SDP) were also introduced with emphasis on transparency, collegiality, partnership, shared decision making, mutual trust and respect for each other’s opinion and a common purpose (Moswela, 2007). These are important attributes of ethical leadership. Despite the government’s emphasis on ethical leadership, concerns about it in schools continue to rise.

Otukile et al. (2020) argue that there were problems of identity crisis and marginalization, a kind of ethical scandal that learners are subjected to in schools in Botswana. Both teaching staff and learners were found to be living in fear or felt insecure, seeking attention, and calling for equal treatment. These emerging challenges could be due to little or no effort being made to ensure that leadership in schools was carried out in an ethical manner by those at the helm of affairs. It is, however, critical to position good governance and ethical leadership into appropriate theoretical lenses.

## **THEORETICAL FRAMEWORK FOR GOOD GOVERNANCE**

Models of development can be placed under two

contradictory positions. There is the Eurocentric economic model. This model is regulated by imperialism, globalization, neo-liberalism, market and money-economy. It has values of stiff competition, greed, individualism, jealousy and competition and is susceptible to conflict and anti-social uprisings. On the other hand, there is the Afrocentric model of “Ubuntu/Botho”. This model is defined by the culture of humanness/humanism, egalitarianism, collectivization, communalism, justice, honesty and ethical behaviour, equality and equity in resource distribution. It is an African human social development approach that cherishes engagement and success for all. Both models (Eurocentrism and Afrocentrism) have had their formal and informal governance orders and codes for which those in leadership positions should apply themselves. However, Africanism of humanness (Ubuntu/Botho) is stronger for social justice communalism. This perspective fits arguments by Olivier (2012) and Shapiro and Stefkovich (2011) on social justice, appropriate organizational leadership that embraces every member of an organization.

The theoretical roots of governance are many, ranging from organizational studies, political science, international relations and institutional economics, to public administration among others (Stoker, 2019) but cannot be divorced from alignment to either Eurocentric or Afrocentric models. However, the demand for effective management and leadership since the first industrial revolution and the models of scientific management by Frederick Winslow Taylor and bureaucratic management by Max Weber in different quarters has led to a shift in focus from mere governance to good governance of emerging formal institutions and/or organizations. Since then, the Eurocentric model with its colonial characteristics dominated institutional leadership practices.

Africa has had its defined ethics and morals of leadership. Botswana’s regard for ethics and morals in leadership is very much reflected in the Setswana culture and traditions of Botho/Ubuntu that dates as far back as the 19th century.

This was clearly illustrated by Denbow and Thebe (2006) that communities in Botswana are governed through an institution known as the Kgotla, (Setswana’s indigenous society’s regulating institution) where matters of economic or political importance to the family or community are discussed. Different segments are in turn grouped around that of the leadership institution known as Kgosi (king) who presides over Kgotla. Under Kgosi, ethics and morals were for social justice and were an embodiment of egalitarianism, collectivization, communalism, reciprocity, dignity, freedom and social harmony. A sense of belonging to a regent or Mophato in Setswana was part of the community organizational structure. Mophato is a regent of people of the same age whose main social and community contract and

commitment was to stand for the values of the society, community wealth, and protection of all members of the community against abuse, hunger and enemy. They were men and women who were prepared to serve their community and cherish values of collective consciousness. So, Mophato members were trained on social and physical skills of compassion and helpfulness, kindness and caring, generosity and sharing and societal integrity and respect (Khoza, 2011). Each Mophato was responsible for social and community development as a collective and built peaceful and united sustainable society characterized by the desire and spirit of connectedness. Values of stiff competition, greed and individualism were not encouraged. This is the Africanized model of ethical leadership that has kept African societies intact until Eurocentrism. Eurocentrism with power of colonization disrupted Africanized model (Ubuntu/Botho) of ethical leadership and replaced it with neoliberal economic perspectives of unstoppable industrial revolution, globalization, market and money economy, trade and values of stiff competition, individual wealth accumulation and of course, conflicts of interest among people and trading partners. This disruption inevitably changed the landscape of Africanized model of ethical leadership. Community leaders or Kgosi lost social leadership control and value systems. Eurocentric politics and economic development preoccupied terms and conditions of social development. Market and money economy controls leadership cultures. Governance models and ethical leadership in any organization, including schools are trapped by this Eurocentric model. This model provides better lenses for which one should appreciate lapses on ethical leadership in the African development setup.

## **DISCUSSING ETHICAL LEADERSHIP LAPSES IN BOTSWANA**

### **Lapses of ethical leadership in Botswana governance system**

From a Eurocentric measure and microscope, the independent Botswana has been perceived and described as the darling of democracy and good governance in Africa. This is due to the country's known prudent financial and economic management, and exceptionally enviable governance operational structures in both the private and public sector. These perceptions were however put to test. Some literature (Good, 1994; Keorapetse and Keakopa, 2012) cast aspersions over the perceptions and concluded that the perception were camouflaged realities despite the existence of the Directorate on Corruption and Economic Crime (DCEC). Keorapetse and Keakopa (2012:27-32) argue that "corruption in Botswana is becoming ominously widespread", with cases of "bribery, conflict of interest, fraud, embezzlement, theft of government assets, money

laundering, tax evasion, and abuse of office", orchestrated by high-ranking officials in political and administrative leadership in partnership with key executives in the private sector and/or entrepreneurship. They recommended that Botswana should consider promulgating suitable polices and/or laws to ward off these cases of corruption. On the contrary, in 2014 through the Public Service Management Directive no 8 of 2014, Botswana introduced and legitimized a system that allows public officers to become entrepreneurs, quite likely making them inevitably more vulnerable to the trap of corruption and other behaviours of unethical conduct than before.

Some recent events in Botswana point to the fact that describing Botswana as the darling of democracy and good governance in Africa is rather said than done. The media is littered with stories of ethical scandals in governance system. Prominent among these events is the leadership contradiction between the current President Dr. Mokgweetsi Keabetswe Masisi and his predecessor, President Lieutenant General Dr. Seretse Khama Ian Khama, which is referred in this discussion as the Masisi-Khama feud. Media stories do show that the quest to consolidate power is the major cause of this feud. As argued by Morton (2019), President Masisi was no longer willing to tolerate the widespread corruption that flourished under his predecessor and this led to the prosecution of the former President Khama's security chief and presidential secretary for alleged corruption. Mokone (2018), reports that Khama allegedly awarded lucrative tenders to Seleka Springs, a company owned by his brother. This allegation leads suspicion of a case of nepotism which is against everything that ethical leadership stands for. It is argued that the Masisi-Khama feud evolved into a political battle that led Khama to leave the ruling Botswana Democratic Party (BDP) in order to disrupt their sustained stay in government through alliances with opposition political parties (Ntshingane, 2019). In the words of Saleshando (2019), the Masisi-Khama feud denied Botswana the opportunity to maturely reflect on the policy proposal presented by the contesting parties, and shifted attention from issues such as creation of employment, decent lives, better quality healthcare and education, and affected the reputation of Botswana on the global stage. Leaving such feud unchecked can result to intolerance which is not typical of ethical leadership. Currently, media reports show that Khama is seeking help from the courts of law to be compensated at the tune of P25 million for reputational damage (Baaitse, 2021). On the other hand, Gabathuse (2020) presents an interview record in which a certain University of Botswana (UB) lecturer, Adam Mfundisi, argues that there is heightened corruption since President Masisi ascended power. This feud of the two most powerful figures raises a lot of questions about "Botho" and quality of ethical leadership in Botswana. It is, therefore, argued here that this Khama-Masisi feud shows that democracy and

ethical leadership are far-fetched in Botswana, and if no successful intervention and remedy is found, Botswana is likely to degenerate into the category of a failing state.

The State of Emergency (SoE) declared, as a result of the COVID-19 pandemic shows that ethical and democratic leadership is claimed to be practiced in Botswana because of the strict laws and not because leaders see them as the right thing to do. After the declaration of six months state of emergency, President Masisi assured Botswana that he will not rule the country by decree which will diminish the values of freedom and other enshrined rights that have made Botswana unique (BW government, 2020). However, in April 2020, he was accused of using the pandemic to crack down on government and media critics (Monitor, 2020). This assertion is backed by several instances in the citations in this article. For example, a certain Rakkie Kelesamine, a school teacher, was arrested after challenging a claim by government that a social worker in parliament tested positive for Covid-19. On another case, a spokesperson of an opposition party was arrested and charged for allegedly maligning and degrading leadership in a Facebook post. There are several concerns over the ability of journalists to freely undertake their work as evidenced by a raid by Directorate of Security Services (DIS) on journalists, an action that was termed by civil society organizations as 'intimidation and harassment', and a direction quite likely towards the trap of a failing state. These media reports indicate that democracy and ethical leadership are far from being the bedrock of Botswana society.

### **Ethical leadership lapses in Botswana schools**

As regards specifics on education, Good (1994) reveals that the malpractice in the award of International Project Managers consultancy known as the IPM consultancy to supply of teaching materials to public primary schools led to more than one million-Pula (Botswana currency = P1 000 000-00) loss in misallocation and delivery of books. This, therefore, means that schools and learners became victims in the process. Furthermore, the school system in Botswana is rocked by incidents of learner identity crisis, marginalization, exclusion (Pansiri, 2011; Marumo and Pansiri, 2016; Otukile et al., 2020), corporal punishment and sexual misconduct (Tafa, 2002; Polelo, 2005; Khudu-Petersen, 2010; Jonas, 2012; Jotia and Pansiri, 2013), corruption and maladministration (Baputaki, 2009; Serite, 2018; Kabelo, 2021). A report by Riddoch and Riddoch (2004) reveals that most of the staff in tertiary institutions in Botswana put little effort in course content, rarely revise syllabus and sometimes plagiarize course outlines and course content. Diraditsile and Rankopo (2018), show that sexual abuse of students exists in Botswana schools, and that many of the female students are negatively affected by this troubling reality.

These revelations point to the fact that school leaders are not doing enough in ensuring that their leadership practices are ethical. This unethical conduct in public service is worrisome even to the law makers.

In the latest revelation, the 2021 Budget Session of Botswana Parliament was informed that in the past five years, the country's Public Service dismissed seven hundred and twenty-seven (727) employees due to cases of unethical conduct (Republic of Botswana, 2021). These cases were recorded during the implementation of the Public Service Management Directive no 8 of 2014, which legitimized public officers to double dip as civil servants as well as entrepreneurs. So, questions about the implication on this policy action on ethical leadership and "Botho" can arise. Out of these dismissals, the Ministry of Basic Education had the second largest dismissals with one hundred and thirty-four (134) mainly school-based cases. The cases are related to theft, persistent absence from work, rape, amorous relationship with students and desertion.

A review of Botswana unethical conduct in schools reveals growing concerns about teacher-student romances in senior secondary schools. For example, the Director of Teaching Service Management (TSM) is reported to have a teacher at Masunga Senior Secondary School investigated following proved complaints about teacher-student romances (Gabathuse, 2008). In another development, two female students at Swaneng Hill School (a senior secondary school) are reported to have fought and injured each other profusely over a male teacher at Boipelego Junior Secondary School (Letsididi, 2009). In terms of unethical teacher leadership conduct, Mathambo (2012) wrote a story about some Maun Senior Secondary School students who burnt the school, protesting student-teacher love affairs.

In terms of theft and maladministration, a certain Oriel School is reported as having Botswana General Certificate of Secondary Education (BGCSE) results investigated for cheating because of alleged suspicions of examination maladministration (Baputaki, 2009). Basimanebotlhe (2017) also wrote about a case of embezzlement in a certain school in the country. According to the author, an inter-ministerial audit at Anne-Stine school uncovered a startling business operation wherein the former board had opened a micro lending scheme with interest set at 20%. In another case, Serite (2018) wrote a story relating to Morale Junior Secondary School head who was accused of fueling corruption and maladministration through her alleged favouritism and discriminatory leadership. In the latest report, Dipholo (2021) wrote about a deputy primary school head at Mokane Primary School who was left with egg on his face after the police arrested him for stealing cooking oil from his school for personal use. These reported cases show education leadership moral standards in decay, a total contradiction of Africanness of "Botho" leadership practice.

## CONCLUSION

This article has demonstrated a contradiction between Eurocentrism and Afrocentrism theories of development and their influence in growing systemic social decadence in the entire fabric of development in Botswana, as well as in increasing cases of unethical conduct in schools. Like any nation-state, Botswana development model is inevitably informed by a Eurocentric theory which is regulated by imperialism, globalization, neo-liberalism, market and money-economy. Greed and personal accumulation are consequential motivators for human satisfaction. Public officers' double-dipping, which is, doing civil service and entrepreneurship in government offices, may not escape the trap of both systematic and systemic development of unethical conduct in the civil service.

The rise in cases of unethical behaviour, the Botswana leadership feud and glaring revelation of the dismissed seven hundred and twenty-seven (727) public service employees due to cases of unethical conduct, in a space of five years, attest to a systemic abhorrent leadership social decadence growing in Botswana. The many recent reported stories about deteriorating ethical standards in schools are also a cause for concern that needs urgent attention to develop codes of moral standards for ethical leadership in schools. The observation on the absence of an Africanized or indigenized code of ethics that community members, teachers and head teachers can relate to in their practice leads to flouting of professional conduct with impunity. More indigenized research and actions are required on the need for Botswana to establish a leadership training policy to guide the training of school leaders and ensure that schools become ethically and morally compliant.

It is, therefore, recommended here that a major step towards promoting ethical leadership in the context of "Botho" in Botswana schools is long overdue. There is need to formulate and institute an indigenized ethical code of conduct framework that embraces African values of Botho/Ubuntu to serve as a guide for pre-service teachers, in-service teachers, school heads and other school leaders. The enactment of such an Africanized framework in the Botswana education system is long overdue, especially, as the several studies and media stories have demonstrated that teachers and school leaders are faced with ethical dilemmas daily. An Africanized ethical leadership framework could serve as an important resort for any educator that is faced with a challenging situation that involves making an ethical decision. The enactment of the Africanized ethical leadership framework should be followed by training, re-training, and new programmes aimed at instilling the tenets of the code of conduct in educators and would-be educators in order to make them appreciate and adhere to the benefits that emanate from being ethical in their conduct.

## LIMITATIONS

This study is limited to Botswana context and so the findings may not be applicable elsewhere. The study was conducted using secondary data which has numerous limitations. First is that the researchers were not involved in the collection of primary data, and so data used may not be particularly reliable and accurate (Johnston, 2014). Again, the data collected may become obsolete with time, and secondary data also raises concerns about authenticity and copyright (Kabir, 2016). Therefore, there is need to conduct further studies in order to ascertain the ethical leadership (EL) perspectives of stakeholders in the education sector in Botswana and the role EL plays in fostering good governance (GG) in schools.

## CONFLICTS OF INTERESTS

The authors have not declared any conflicts of interests.

## REFERENCES

- Atuobi MS (2007). Corruption and state instability in West Africa: An examination of policy options. Available at <https://reliefweb.int/sites/reliefweb.int/files/resources/9BD8A1F729CEB5B8C125746C0049D740-kaiptc-dec2007.pdf>. Accessed 28 September 2020.
- Baaitse D (2021). Uphill battle in khamas's quest to charge Hubona. Available at <https://www.weekendpost.co.bw/31130/news/uphill-battle-in-khamas-quest-to-charge-hubona/>. Accessed 19 May 2021.
- Bah AB (2012). State decay: A conceptual frame of failing and failed states in West Africa. *International Journal of Politics, Culture and Society* 25:71-89.
- Baputaki C (2009). Oriell's BGCSE results investigated for cheating. Mmegionline, 18 February. Available at <https://www.mmegi.bw/index.php?sid=1andaid=7anddir=2009/February/Wednesday18/>. Accessed 13 February 2021.
- Basimanebotho T (2017). Maladministration rocks Anne-Stine school in Moleps. Mmegionline, July 14. Available at <https://www.mmegi.bw/index.php?aid=70277anddir=2017/july/14>. Accessed 13 February 2021.
- Brinkerhoff WD, Brinkerhoff MJ (2002). Governance reforms and failed states: Challenges and implications. *International Review of Administrative Sciences* 68(4):511-531.
- BW government (2020). Masisi pledges no abuse of power. Available at [https://m.facebook.com/story.php?story\\_fbid=2889064511176188andid=148228411926492](https://m.facebook.com/story.php?story_fbid=2889064511176188andid=148228411926492). Accessed 3 May 2021.
- Cheeseman N (2015). *Democracy in Africa successes, failures, and struggle for political reform*. Cambridge: Cambridge University Press. <https://doi.org/10.1017/CBO9781139030892>
- Cheteni P, Shindika ES (2017). Ethical leadership in South Africa and Botswana. *Brazilian Administration Review* 14(2):1-12.
- Chigbu UE (2011). On grooming good governance in Africa: A scrutiny on good governance in the African family. *Contemporary Journal of African Society* 1(1):114-133.
- Denbow J, Thebe CP (2006). *Culture and customs of Botswana*. London: Greenwood Press.
- Dipholo K (2021). School Head in Hot Soup over Stolen Cooking Oil. *The Voice*, 20 January. Available at <https://news.thevoicebw.com/2021/01/school-head-in-hot-soup-over-stolen-cooking-oil/>. Accessed 13 February 2021.
- Diraditsile K, Rankopo MJ (2018). Students' views and experiences on child sexual abuse in Botswana: Implications for educational research and policy implementation. *Mosenodi Journal* 21(20):66-79.



- Eranil AK, Ozbilen FM (2017). Relationship between school principals' ethical Leadership behaviours and positive climate practices. *Journal of Education and Learning* 6(4):100-112.
- Forster DJ (2012). Codes of ethics in Australian education: Towards a national perspective. *Australian Journal of Teacher Education* 37(9):1-17.
- Fukuyama F (2013). "What is governance?" CGD Working Paper 314. Washington, DC: Center for Global Development. Available at [https://www.files.ethz.ch/isn/159182/1426906\\_file\\_Fukuyama\\_What\\_Is\\_Governance.pdf](https://www.files.ethz.ch/isn/159182/1426906_file_Fukuyama_What_Is_Governance.pdf). Accessed 8 September 2020.
- Gabathuse R (2020). President Masi and Corruption fight. Mmegionline 18 September. Available at <https://www.mmegi.bw/index.php?aid=87077&dir=2020/september/18>. Accessed 12 May 2021.
- Gabathuse R (2008). Teacher-student romance annoys TSM director. Mmegionline, 30 July. Available at <https://www.mmegi.bw/index.php?sid=1&aid=7&dir=2009/February/Wednesday18/>. Accessed 16 April 2021.
- Gaisselquist RM (2012). Good governance as a concept, and why this matters for development policy. Available at [https://www.researchgate.net/publication/239810900\\_Good\\_Governance\\_as\\_a\\_Concept\\_and\\_Why\\_This\\_Matters\\_for\\_Development\\_Policy](https://www.researchgate.net/publication/239810900_Good_Governance_as_a_Concept_and_Why_This_Matters_for_Development_Policy). Accessed 9 September, 2020.
- Good K (2009). Briefing the presidency of General Ian Khama: The militarization of the Botswana 'miracle'. *African affairs* 109(435):315-324.
- Good K (1994). Corruption and mismanagement in Botswana: A best-case example? *The Journal of Modern African Studies* 32(3):499-521.
- Head T (2017). Durban teacher suspended after his relationship with a 14-year-old pupil went public. Available at <https://www.thesouthafrican.com/news/durban-teacher-suspended-after-his-relationship-with-a-14-year-old-pupil-went-public/>. Accessed 9 September 2020.
- Jawondo IA (2011). Political violence and the attainment of democratic culture in Nigeria. *International Journal of History* 3(3):147-160.
- Jespersen E (1992). External shocks, adjustment policies and economic, and social performance. In Cornia et al., (eds.). *Africa's recovery in the 1990s, from stagnation and adjustment to human development*. St Martin's Press: New York.
- Johnston M (2014). Secondary data analysis: A method which the time has come. *Qualitative and Quantitative Methods in Libraries* 3(3):619-626.
- Jonas O (2012). Corporal punishment in Botswana schools: A human right perspective. *International Journal of Law and Education* 17(2):75-97.
- Jotia LA, Pansiri ON (2013). Multicultural education: the missing link in Botswana education policy. *European Journal of Educational Studies* 5(1):101-110.
- Kabelo D (2021). School head in hot soup over stolen cooking oil. *The Voice* 20 January. Available at <https://news.thevoicebw.com/2021/01/school-head-in-hot-soup-over-stolen-cooking-oil/>. Accessed 13 February 2021.
- Kabir SMS (2016). *Methods of data collection. In basic guidelines for research: An introductory approach for all disciplines (1<sup>st</sup> ed.)*. Chittagong, Bangladesh: Book Zone Publication.
- Keorapetse LD, Keakopa MS (2012). Records management as a means to fight corruption and enhancing accountability in Botswana. *Journal of the Eastern and Southern Africa Regional Branch of the International Council on Archives* 30:22-36.
- Khoza RJ (2011). *Attuned leadership: African humanism as compass*. Johannesburg: Penguin.
- Khudu-Petersen K (2010). *Intercultural arts education: Initiating links between schools and ethnic minority communities focusing on the Kweneng west sub-district in Botswana*. PhD dissertation. United Kingdom, Edinburgh: University of Edinburgh.
- Kgomotlokoa LT, Matshidiso MK, Stephen M, Newman W (2016). The importance of ethics of caring in South African higher education. *Journal of Social Sciences* 47(1):90-97.
- Klitgaard R (1988). *Controlling corruption*. California: University of California Press.
- Komal K, Sheher B (2015). Can ethical leadership enhance individual's task initiative? *Journal of Business Law and Ethics* 3(1):62-84. <https://doi.org/10.15640/jble.v3n1a4>
- Letsedidi B (2009). Teacher-student love affairs are intolerable. Mmegionline, 17 April. Available at <https://www.mmegi.bw/index.php?sid=1&aid=7&dir=2009/February/Wednesday18/>. Accessed 16 April 2021.
- Lord P Martin K Atkinson M, Mitchell H (2009). *Narrowing the gap in outcomes: What is the relationship between leadership and governance?* Slough: National Foundation for Educational Research.
- Maria G, Valts K (2017). *Codes of conduct for teachers in Europe: A background study (vol. 4)*. Strasbourg: Council of Europe Publishing.
- Marumo BB, Pansiri (2016). Early school withdrawals and underperformance as indicator of poor attention to learner's welfare: Botswana in 50 years of self-rule. *Journal of Education Issues* 2(2):367-384.
- Mathambo B (2012). 'Students' Burn Maun SSS. Mmegionline, 15 October. Available at <https://www.mmegi.bw/index.php?sid=1&aid=71&dir=2012/October/Monday15/>. Accessed 12 May 2021.
- Miller A (2014). Five characteristics shared by the most successful organizations. Available at <https://www.entrepreneur.com/article/233526>. Accessed 8 September 2020
- Mokone O (2018). The Myth of the Masi-Khama feud. *Sunday Standard*, 27 November. Available at <https://www.sundaystandard.info/the-myth-of-the-masi-khama-feud/>. Accessed 5 May 2021.
- Monitor (2020). Authorities accused of abusing COVID-19 restrictions to stifle expression despite improved ranking, 30 May. Available at <https://monitor.civicus.org/updates/2020/06/30/authorities-accused-abusing-covid-19-restrictions-stifle-expression-despite-improved-ranking/>. Accessed 3 May 2021.
- Morton B (2019). How Masi outsmarted Khama to take the reins in Botswana. *The Conversation*, 6 November. Available at <https://theconversation.com/how-masi-outsmarted-khama-to-take-the-reins-in-botswana-126150>. Accessed 3 May 2021.
- Moswela B (2007). An investigation into democratic practices in Botswana primary schools. *South African Education Journal* 4(1):14-28.
- Mukadder BO, Tuncay YO, Ramazan Y (2017). Ethical leadership behaviours of school administrators from teacher's point of view. *Foro de Educacion* 15(23):161-184. <http://dx.doi.org/10.14516/fde.520>
- Naidoo EM (2015). *Ethical leadership in schools: voices of school principals and teachers from three secondary schools in Durban*. Available at <http://researchspace.ukzn.ac.za/xmlui/handle/10413/13770>. Accessed 9 September 2020.
- Ntshingane B (2019). Masi-Khama feud puts the presidency at a crossroads. Mmegionline, 1 November. Available at <https://www.mmegi.bw/index.php?aid=83308&dir=2019/november/01>. Accessed 3 May 2021.
- Ojo JS (2018). *Politics of corruption in Africa*. In A Farazmad (ed.). *Encyclopedia of Public Administration, Public Policy, and Governance*. New York: Springer International Publishing. [https://doi.org/10.1007/978-3-319-31816-5\\_3556-1](https://doi.org/10.1007/978-3-319-31816-5_3556-1)
- Okagbue BO (2012). *Ethical leadership and good governance in Nigerian local governments*. PhD dissertation. Massachusetts, Walden: Walden University.
- Olivier A (2012). How ethical is leadership? *Leadership* 8(1):67-84.
- Oramadike V (2020). Delta government demotes 41 teachers for examination malpractice. *Channelstv News*, 21 September. Available at <https://www.channelstv.com/2020/09/21/delta-govt-demotes-41-teachers-for-examination-malpractice/>. Accessed 21 September 2020.
- Otukile NM, Mabua M, Pansiri ON (2020). Identity crisis and exclusion in schools: a challenge for school leadership in Botswana. *International Journal of Social Sciences* 30(1-3):77-87.
- Pagones S (2020). Chinese teacher who poisoned 25 kindergartners out of 'revenge' sentenced to death. *Fox News*, 28 September. Available at <https://www.foxnews.com/world/chinese-teacher-poisoned-kindergartners-sentenced-death>. Accessed 30 September, 2020.

- Pansiri NO, MphathiwaL, Iloanya J, Ugwu CI, Tsae B (2021). Ubuntu as a sustainable philosophy for school leadership and governance: the Botswana and Nigeria Conflict (pp 172 – 188). In J. Mukuni and J. Tlou. (Eds). *Understanding Ubuntu for Enhancing Intercultural Communications*. IGI Global: Hershey PA, USA.
- Pansiri ON (2011). Silent exclusion: the unheard voices in remote areas of Botswana. *International Journal of Social Sciences* 3(2):109-118.
- Polelo MM (2005). School dropout among the remote area dwellers of Botswana: A socio-cultural analysis. *Pula: Botswana Journal of African Studies* 19(1):85-102.
- Republic of Botswana (2014). *Public Service Management Directive No. 8 of 2014 Review of Condition of Service for Public Service*. Gaborone: Directorate of Public Service management.
- Republic of Botswana (2021). *Hansard of the Botswana National Assembly*. Gaborone: Government Printers.
- Riddoch I, Riddoch BJ (2004). A question of ethics: Tertiary-level teaching in Botswana. Available at <https://ejournals.bc.edu/index.php/ihe/article/download/7398/6595/>. Accessed 22 September 2020.
- Sabre C, Keith DW, Benjamin K (2015). Principals' moral agency and ethical decision making: toward a transformational ethics. *International Journal of Education Policy and Leadership* 10(5):1-17. <http://dx.doi.org/10.22230/ijepl.2015v10n5a572>
- Saldana J (2013). Power and conformity in today's schools. *International Journal of Humanities and Social Science* 3(1):228-232.
- Saleshando D (2019). "When two elephants fight, it is the grass that suffers" Sales handoon Masisi-Khama Feud. Available at [https://web.facebook.com/TheWeekendPostBW/videos/1352098964949629/?\\_rdc=1and\\_rdr](https://web.facebook.com/TheWeekendPostBW/videos/1352098964949629/?_rdc=1and_rdr). Accessed 3 May 2021.
- Serite S (2018). Morale sec. school marred in corruption and maladministration-allegation. *The Botswana Gazette*, 22 November. Available at <https://www.thegazette.news/news/morale-sec-school-marred-in-corruption-and-maladministration-allegations/24913/#.YChAao9KjIU>. Accessed 13 February 2021.
- Shacklock AH, Lewis MJ (2006). Leading with integrity: A fundamental principle of integrity and good governance. *World Ethics Forum 2006 Conference Proceedings*. Available at [https://research-repository.griffith.edu.au/bitstream/handle/10072/18843/45987\\_1.pdf](https://research-repository.griffith.edu.au/bitstream/handle/10072/18843/45987_1.pdf). Accessed 9 September 2020.
- Shapiro JP, Stefkovich JA (2011). *Ethical Leadership and Decision Making in Education: Applying Theoretical Perspectives to Complex Dilemmas* (3<sup>rd</sup>ed.). New York: Routledge Taylor and Francis.
- Sharmini SV, Azlin NM, Mohd H, Khadijah AR (2018). Influence of ethical leadership practices on teacher work engagement at high performing secondary schools: A case study. *Journal of Advanced Research in Dynamical and Control Systems* 10(12):1397-1403.
- Stoker G (2019). Governance as theory: Five propositions. *International Social Science Journal* 50:17-28.
- Tafa EM (2002). Corporal Punishment: The brutal face of Botswana's authoritarian schools. *Educational Review* 54(1):17-26.
- Teachers Registration Council of Nigeria Code of Conduct (2013). Available at <https://trcn.gov.ng/PUBLICATION/CODE%20OF%20CONDUCT.pdf>. Accessed 19 September 2020
- Utah Educational Leadership Toolkit 5 (2019). Available at <https://www.schools.utah.gov/file/d4331a0b-6100-4c9e-a887-ca542b929ad1>. Accessed 8 September, 2020.
- United Nations Economic and Social Commission for Asia and the Pacific (UNESCAP) (n.d). What is good governance? Available at <https://www.unescap.org/sites/default/files/good-governance.pdf>. Accessed 8 September, 2020.
- Zaleha O, Rashidah AR (2014). Attributes of ethical leadership in leading good governance. *International Journal of Business and Society* 15(2):359-372.

**Related Journals:**

