

*Full Length Research Paper*

# Optimization of harmonics formed in asynchronous motors through SPWM and genetic algorithms

Metin Doğan<sup>1\*</sup>, Mustafa Dursun<sup>1</sup>, Ali Fuat Boz<sup>2</sup> and Gökhan Poyraz<sup>1</sup>

<sup>1</sup>Department of Electrical Education, Duzce University, Duzce, Turkey.

<sup>2</sup>Department of Electronic-Computer Education, Sakarya University, Sakarya, Turkey.

Accepted 13 June, 2011

**This study on the elimination of harmonics which form in three-phase asynchronous motors driven by inverters uses genetic algorithms (GA), one of the optimization methods, to suppress the undesired harmonics. By the use of Matlab/Simulink program, the study aims to identify the optimum switching angles in the optimum number. Optimum switching angles are the angles which make the first harmonic amplitude the biggest and the harmonic largest first-harmonic amplitudes which is to eliminated the smallest. The model has been developed by using sinusoidal pals width modulation (SPWM) technique in simulink environment. No technical help of this model using the (standard condition) the harmonic values, the values of the harmonic occurred by using SPWM and the results obtained with GA is presented in tables and graphs and analyzed the differences between them. As a result, greatly reduced of harmonics clearly shown also with the help of graphs in the study made with GA.**

**Key words:** Genetic algorithms, elimination of harmonics, inverter, sinusoidal PWM (SPWM).

## INTRODUCTION

As drive systems, electric motors are the indispensable elements of the industry. Asynchronous motors are more commonly used in the industry compared to other electric motors due to their strong and powerful structures, low costs, low sound and inertia levels, less need for maintenance especially in the squirrel-cage types and their ability to work in polluted and precarious environments. Having a wider power and speed range is another advantage of asynchronous motors. In order for the electric power systems and related electric motors to work defect-free and in a safe manner, it is required that the wave type in the system to be sinusoidal and to have a single frequency of 50 Hz. However, as a result of some elements that connect to the system and some

events; current and voltage sizes lose their sinusoidal characteristics and cause the existence of undesired harmonics. It has been known for years that nonlinear loads produce distortions in the voltage and current wave types in electric distribution systems. However as a result of vast proliferation of power electronics elements in addition to the existing nonlinear loads, an increase in the number of elements that are sensitive to distortion in wave types have been observed which has raised the importance of studies in the field (Sarioglu, 1983; Boduroglu, 1988; Nabiyeve, 2003). One of the techniques that reduce harmonics distortion is pals width modulation (PWM). PWM techniques and strategies to obtain sinusoidal output voltage have been studied extensively since 1970s. The harmonics content in the inverter output may be reduced through the use PWM (Jeevananthan, 2007). The main problems of harmonics both in synchronous and asynchronous motors are the increase in iron and copper losses, warming due to high voltage caused by harmonics and the decrease in efficiency. While harmonics may cause oscillations in motor momentum, high voltages may bring about loud sound levels in these motors (Dugan, 1996). Main approach in

\*Corresponding author. E-mail: metindogan@duzce.edu.tr.

**Abbreviations:** GA, Genetic algorithms; SPWM, sinusoidal pals width modulation; PWM, pals width modulation; AC, alternating current; DC, direct current; IGBT, insulated gate bipolar transistor; GTO, gate turn off transistors; SCR, silicon controlled rectifier; THD, total harmonic distortion.

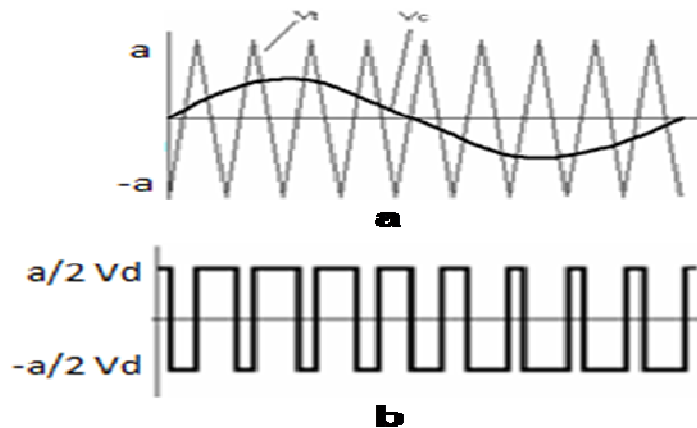

**Figure 1.** Formation of SPWM. **a**, control signal by porter wave; **b**, SPWM output wave shape (Yumurtaci, 2007).

the PWM technique is the comparison of a reference signal and a transport signal. When the reference signal is larger than transport signal the outgoing signal is positive whereas it is negative in conditions where the reference signal is smaller than the transport signal. The intersection points of the signals C show the commutating time of power electronics switching elements (Karanun, 2002). The aim of using the PWM technique is to reduce the total harmonic distortion (THD) levels in the inverter output, eliminate desired harmonics, minimize the filtration requirements, increase voltage amplitude and minimize switching losses (Zhou, 2002; Jeevananthan, 2005). PWM technique is used extensively in voltage supplied inverters, alternating current (AC) motor drive applications, direct current (DC) network controlled rectifier applications and AC power transformation. Transporter based PWM methods are preferred in many voltage based inverter drives due to the fixed switching frequencies, low voltage surge and good harmonics spectrum characteristics (Hava, 1999). Generally two application techniques-triangle intersection technique and direct digital method are used for transporter based methods. In the triangle intersection technique, a reference signal and a triangle signal is compared in order to produce a PWM signal. Direct digital method requires the calculation of duty cycle for each sampling period in the space-vector modulation (Sundvall, 2007).

Although high current and voltage distortions caused by harmonics can be reduced significantly by using PWM technique, they cannot be completely eliminated due to the switching losses of the power electronics elements. Prior identification of power electronics switching elements used in PWM by artificial intelligence can significantly reduce these losses.

The most commonly used type of artificial intelligence is genetic algorithm (GA) technique. Gas are computer

based problem solving techniques that use natural evolutionary processes as models. Multi dimensional optimization problems that are difficult to solve through traditional programming techniques can be solved in a speedy and easy manner through the use of GAs (Goldberg, 1989). GAs do not look for random solutions for a specific problem. They implement selective based search in order to find desired individuals from these random results by utilizing crossover and mutation operators (Holland, 1992). This study aims to eliminate harmonics formed in asynchronous motors driven by three-phase inverter in Matlab/SIMULINK environment by using GA logic.

### SINUSOIDAL PWM (SPWM) TECHNIQUE

In this method, impact is produced in intersections by comparing one reference sinusoidal wave in the frequency desired to be created in output with a porter triangle wave in the switching frequency. The basic voltage constituent and frequency of the DGM wave in Figure 1 is controlled by reference wave amplitude and frequency (Sarioglu, 2003; Ertan, 1994):

$$\text{If } V_C > V_t ; \text{ then } V_{R0} = a/2 V_d$$

$$\text{If } V_C < V_t ; \text{ then } V_{R0} = -a/2 V_d$$

Here  $V_C$ , reference sinusoidal wave amplitude;  $f$ , frequency;  $V_t$ , porter wave point amplitude;  $f_s$ , switching frequency;  $m_a$ , modulation index;  $m_f$ , modulation ratio.

$$m_a = \frac{V_C}{V_t} \quad m_f = \frac{f_s}{f} \quad (1)$$

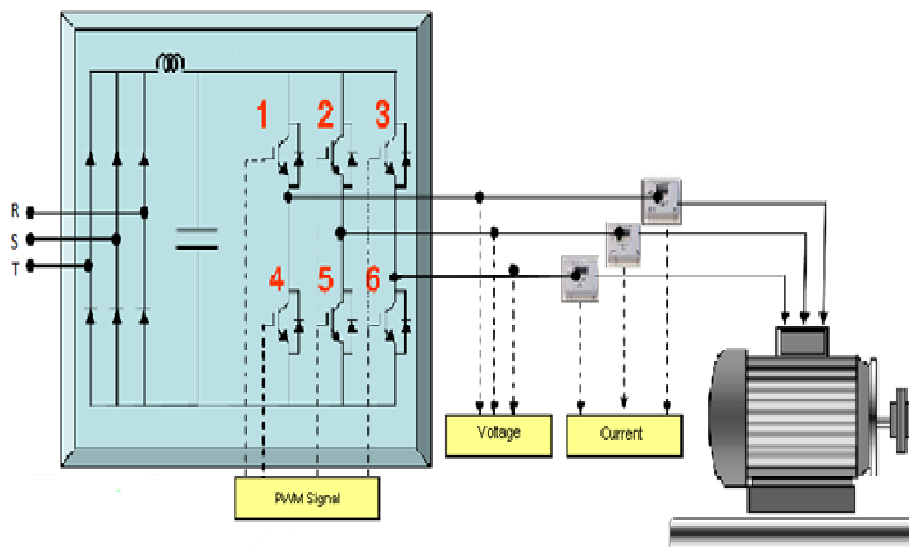

Figure 2. Three-phase PWM inverter (Antonio, 2010).

Modulation index has four conditions (Mohan et al., 2003) if  $m_a=0$ ; there will be square waves in output switching frequency. if  $0 \leq m_a \leq 1$ ; linear changes with the basic constituent peak value  $(V_{RO})_1 m_a$ :

$$(V_{RO})_1 = m_a \frac{V_d}{2} \quad (2)$$

if  $m_a=1$ ; basic constituent takes the value of  $a/2V_d$ . The value that is the maximum for the linear area corresponds to 78.55% of the square wave condition which is the maximum value that the inverter can create ( $4V_d/2\pi$ ) (Bose, 2002), If  $m_a > 1$ ; extreme modulation area. In this area, linearity is disrupted. Square wave is formed after a certain value of  $m_a$ .

Extreme modulation is defined as working in conditions where modulation index is larger than 1 which shows that reference wave amplitude has exceeded the porter wave amplitude. In order to obtain a balanced three-phase voltage in the three-phase SPWM inverter output, the same triangle wave is compared with  $120^\circ$  phase three different sinusoidal control points. Intersection points determine the switching moments.

### THREE-PHASE INVERTER SYSTEM

Basically inverters convert DA energy into AA energy whose amplitude and frequency can be adapted. DA voltage in the input can be fixed or variable. AA output is obtained with switching processes and the obtained wave shape consists of voltage particles. The aim here is to

produce a voltage whose amplitude and frequency can be controlled. The inverters working in switching mode are used in a wide field including AA motor drive systems, continuous power resources and induction heating. This study utilizes the commonly used DGM type inverters (Bose, 2002; Vithayathil, 1995; Bellar, 1998).

In PWM, inverter output voltage wave form has fixed amplitude. Variable output voltage is obtained by switching the source voltage in regular periods.

Output voltage is determined by adjustment of signal width in each cycle. In these types of inverters, switching elements are transistor types such as insulated gate bipolar transistor (IGBT) or gate turn off transistors (GTO). With the help of these transistors a higher switching frequency is obtained compared to silicon controlled rectifier (SCR) type traditional elements (Ashfaq, 1999). Although square wave output voltage is suitable for some applications, the ideal output voltage format is sinusoidal. There are two methods to obtain sinusoidal output wave forms: the first one is the use of filters in the inverter output side but this method can cause extra power loss and the second one is the wave format modification through regulating switching process (Ashfaq, 1999, Yedemale, 2005). Figures 2 and 3 display the SPWM inverter and wave forms.

### ELIMINATION OF HARMONICS AND CALCULATION OF SWITCHING ANGLES

This method is based on pre-calculation of switching angles that can control the amplitude of basic harmonics

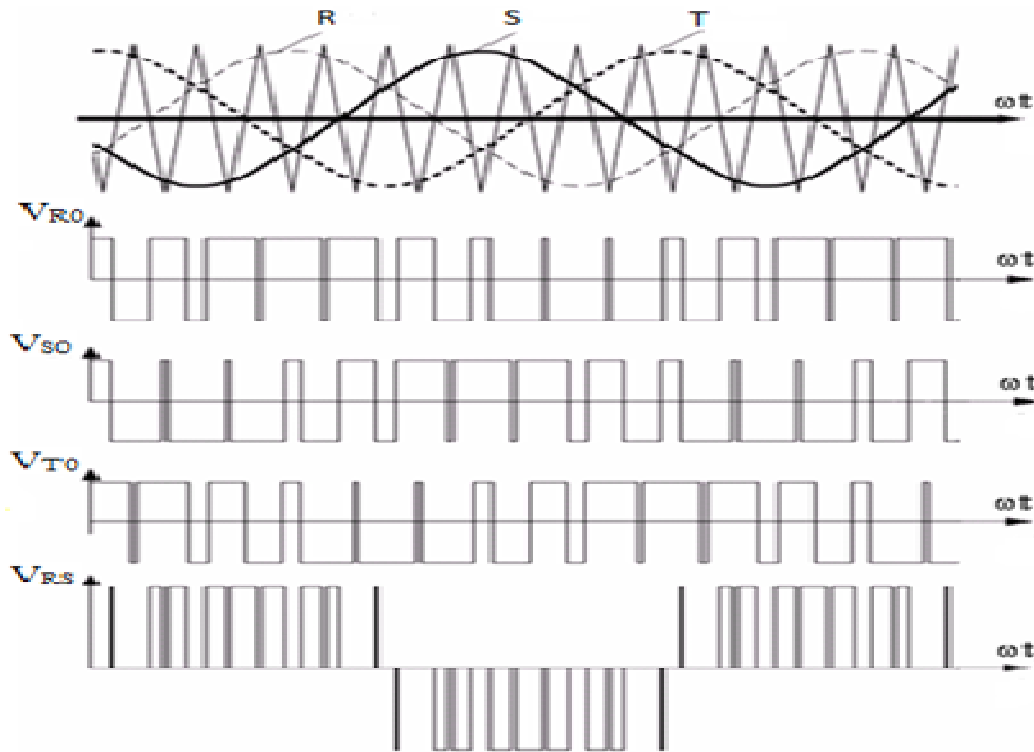

Figure 3. Voltage wave shapes for three-phase SPWM (Incekara, 2000).

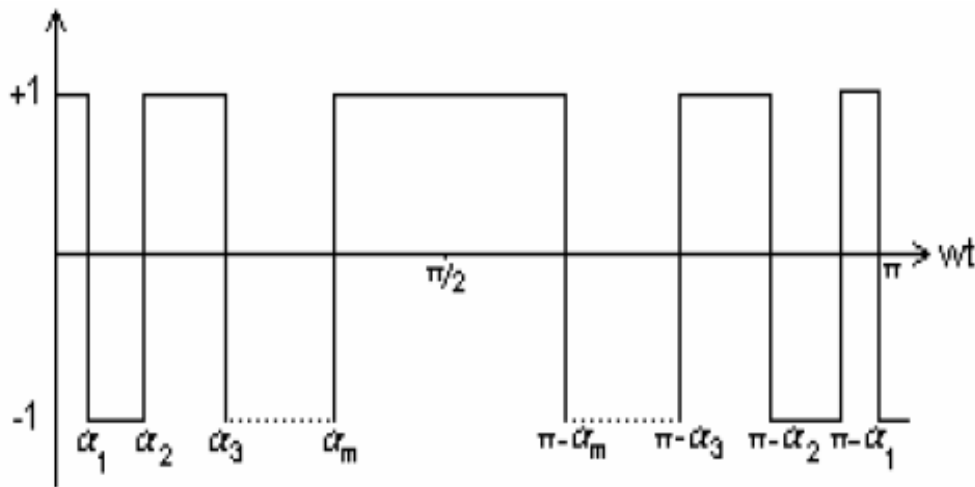

Figure 4. General diagram of inverter polar voltage (Gursu, 2005).

and eliminate the unwanted harmonics in voltage of the inverter with PWM. Hence there is a certain relationship between the harmonics number that will be eliminated and the switching number. Figure 4 displays a generalized one phase inverter polar voltage with PWM

that has half and quarter wave symmetry. Here odd number indexed switching angles such as  $\alpha_1, \alpha_3$  are defined as angles to negative transition whereas even number indexed switching angles such as  $\alpha_2, \alpha_4$  are defined as angles to positive transition. When this sign is

opened to Fourier series, it will be seen that it is comprised of only odd numbered sinus constituents due to the symmetrical nature of the wave shape (Gursu, 2005).

The harmonics constituents of this sign are calculated through Fourier analysis. In general, the Fourier equation:

$$f(\theta) = \frac{a_0}{2} + \sum_{n=1}^{\infty} [(a_n \cos n\theta) + (b_n \sin n\theta)] \tag{3}$$

$$a_n = \frac{2}{T} \int_0^T V_o(t) \cos n\theta dt \tag{4}$$

$$a_n = \frac{2}{T} \int_0^T V_o(t) \cos n\theta dt \tag{5}$$

$$b_n = \frac{2}{T} \int_0^T V_o(t) \sin n\theta dt \tag{6}$$

Due to quarter wave symmetry  $a_n = 0$ :

$$b_n = \frac{2}{2\pi} \int_0^{2\pi} \sin n\theta d\theta \tag{7}$$

Since the wave shape is symmetrical around  $\pi/2$ :

$$b_n = \frac{4}{\pi} \left[ \int_0^{\pi/2} \sin n\theta d\theta - \int_{\pi/2}^{\pi} \sin n\theta d\theta + \int_{\pi}^{3\pi/2} \sin n\theta d\theta - \int_{3\pi/2}^{2\pi} \sin n\theta d\theta + \dots \right] \tag{8}$$

$$b_1 = \frac{4}{\pi} [1 - 2\cos\theta_1 + 2\cos\theta_2 - 2\cos\theta_3 + \dots + 2\cos\theta_n \dots] \tag{9}$$

$$b_3 = \frac{4}{3\pi} [1 - 2\cos 3\theta_1 + 2\cos 3\theta_2 - 2\cos 3\theta_3 + \dots + 2\cos 3\theta_n \dots] \tag{10}$$

Then; the general equation:

$$b_n = \frac{4}{n\pi} [1 - 2\cos n\theta_1 + 2\cos n\theta_2 - 2\cos n\theta_3 + \dots + 2\cos n\theta_n \dots] \tag{11}$$

The aim of harmonics elimination in the inverter which is to find the switching angles that suppress the undesired harmonics and to maximize basic harmonics in  $b_n$  general equation is a multi variable and multi restricted optimization problem. In the solution of this problem, Matlab program based on GA will be used (Gursu, 2002).

**GENETIC ALGORITHMS**

GA are a part of evolutionary calculations. This field is a branch of artificial intelligence which is rapidly advancing. GA are inspired by theory of evolution. To explain it simply, the solutions are approximated by the help of an evolutionary process in order to reach the best solution with the best result. GAs are used in solving problems that are difficult or impossible to solve with traditional

methods. In general, fields of application for GAs are optimization in experiential studies, practical industrial applications and classification systems and it has now been used in engineering problems with the aim of optimization (Yildiz, 2008). GAs are especially known to produce the best results in mechanism designs (Konuralp, 1998). In addition to these, GAs are used in automatic control, intelligent motors, economics, ecology, planning, production line lay-out. GAs find many fields of applications in digital art processing (Manfield, 1990; Gizolme, 1998). Almost all of these problems require the reviewing of a very wide solution domain. It takes a rather long time to review the solution domain with traditional methods, however genetic algorithms help reach acceptable solutions in a shorter time (Figure 5).

Algorithm starts with a solution set called population which consists of chromosomes each of which constitutes a solution for the problem. The function that determines the degree of suitability of the chromosomes in the initial population which is created randomly is called fitness function. Each candidate is tested according to the fitness function. Selection operator is responsible from the identification of chromosomes that will be involved in crossover. This operator is named natural selection operator and works according to the principle of survival of the fittest. Crossover is undertaken with the aim of creating more suitable generations by taking the desired parts from previous generations. Crossover is the exchange of genetic information of the two chromosomes by coming together. This element makes it possible to test the chromosome configurations. Mutation is attempted to create chromosomes with a higher suitability value when it is not possible to do it with crossover method, to prevent the new solutions from copying the previous solution, to find new, original and unprecedented elements for solution and to reach the solution faster (Holland, 1992).

**Identification of optimum switching angles by GA**

The Matlab program that takes the suitability value as found following the equation “fitness function=absolute value of the first harmonics (minus) absolute value of the total of other harmonics that are required to be eliminated (plus) number that will not cause the fitness function to be negative” works following these steps:

The values and data for the following are entered: harmonics number that will be eliminated, number of population, the number of maximum generations, whether the harmonics with a value of 3 and its multiplications will be eliminated, how many more angles is required from the harmonics number that will be eliminated in order to be able to make the elimination, harmonics coefficient starting from the third harmonics, and how many harmonics want to be seen as graphics

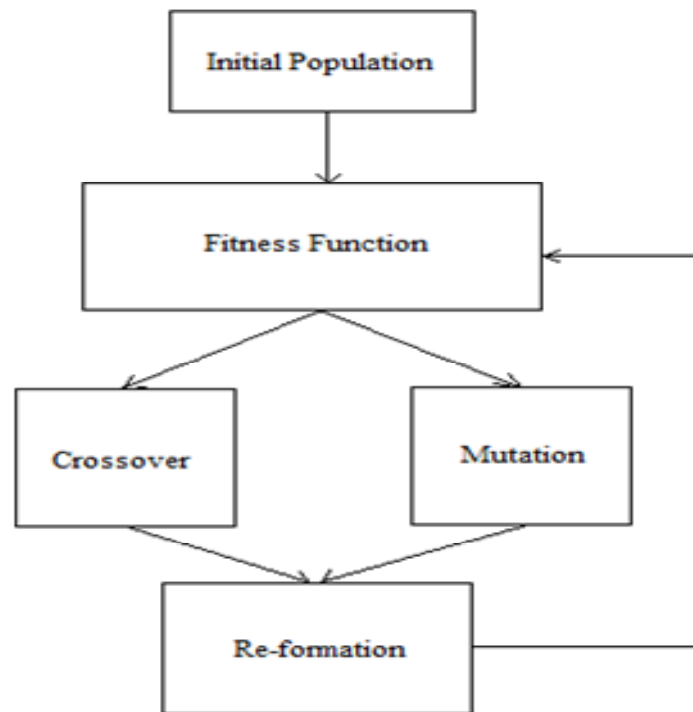

Figure 5. GA flow diagram.

and values. Separate numbers that match the number of population for the initial generation are produced randomly.

These random angular values produced separately for each population are placed in the bn general equation and harmonics are calculated. Suitability and average suitability is calculated. Scaled suitability values and the copy numbers according to these values are calculated. The angular values in the initial generation are calculated according to a specific rule (if the population number is 10, crossover among populations 1-10, 2-9, 3-8, 4-7, 5-6).

If the generation number is smaller than the maximum generation number it is increased one point. New harmonics and new suitability values are calculated according to these new values. The population angles with the biggest suitability value are selected by comparing the previous calculations with the suitability of each population separately that are calculated as a result of crossover. Suitability averages of these populations are calculated. If the resulting suitability average is smaller or equal to the previous suitability average (if the crossover has not been successful) mutation process is started. One bite of the randomly selected last angles is mutated and new angles are created. New suitability values are calculated according to the new angles formed

as a result of the mutation. If these new suitability values are bigger than the previous suitability values, the angles of each large suitability value to their populations are selected. If the number of generation is bigger than the maximum generation number angles with the biggest suitability values are selected in all generations. The number of harmonics that are required to be obtained according to these angles are calculated and the amplitude spectrum is drawn. In the program it is also possible to include harmonics that will be repressed. By choosing these weights, each harmonics can be repressed in the desired degree or can be kept at the desired level (Gursu, 2002).

#### **Standard asynchronous motor current, angular speed, electromagnetic torque and harmonic distortion situation**

Figure 6 displays 3-phase asynchronous motor stator current, angular speed and electromagnetic torque graphics that are obtained from asynchronous motor found ready in Matlab Simulink environment. Figure 7 displays the graphic for voltage among phases that are obtained from asynchronous motor found ready in Matlab Simulink environment.

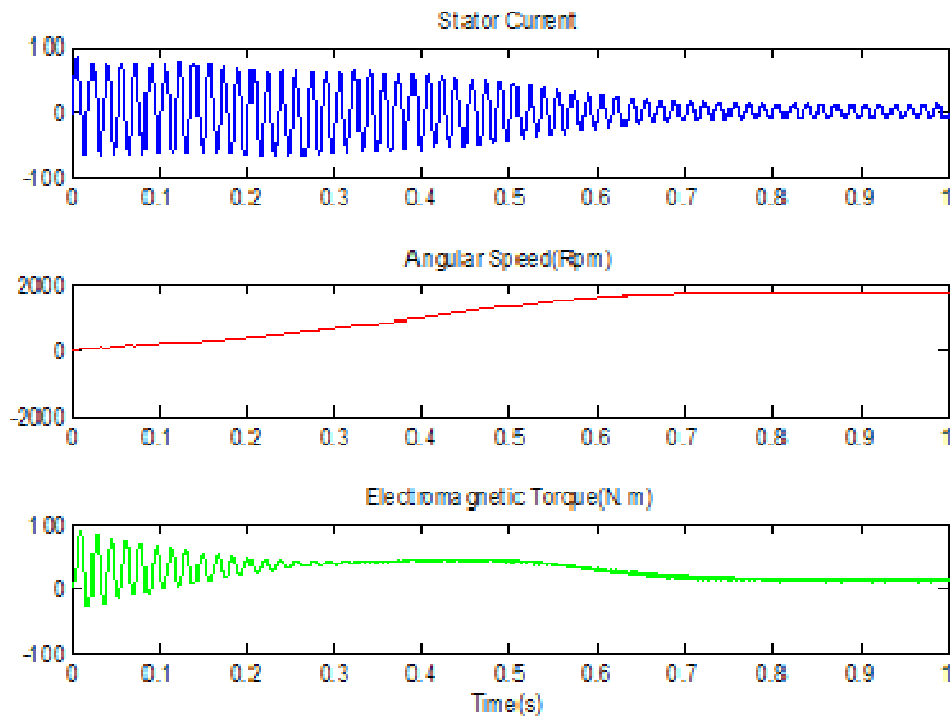

**Figure 6.** Three phase asynchronous motor stator current, angular speed and electromagnetic torque graphics.

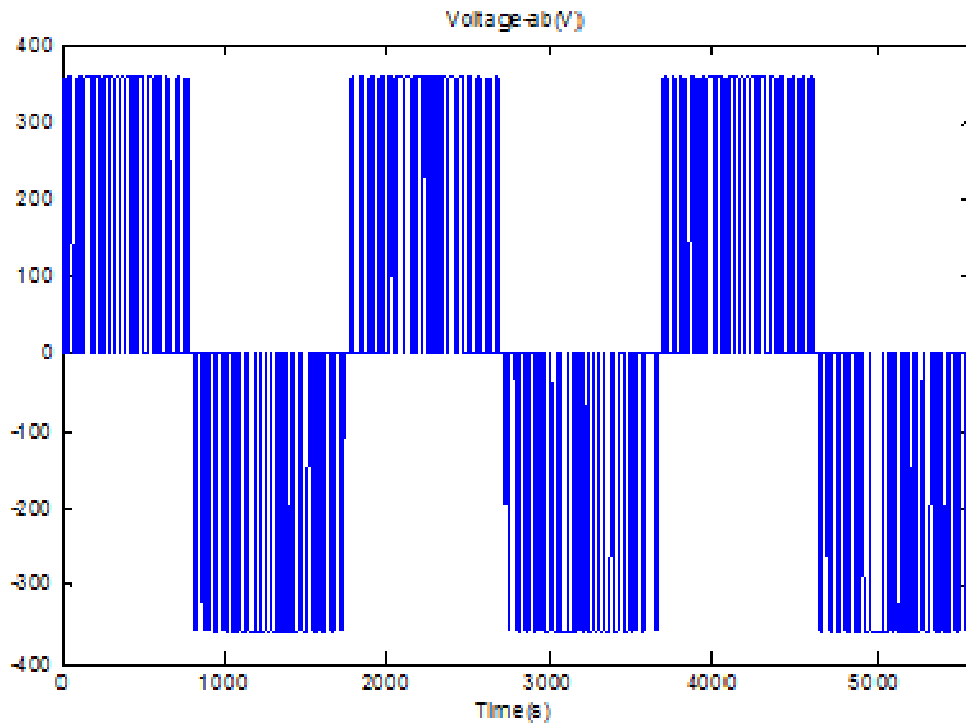

**Figure 7.** Phase to phase voltage of inverter.

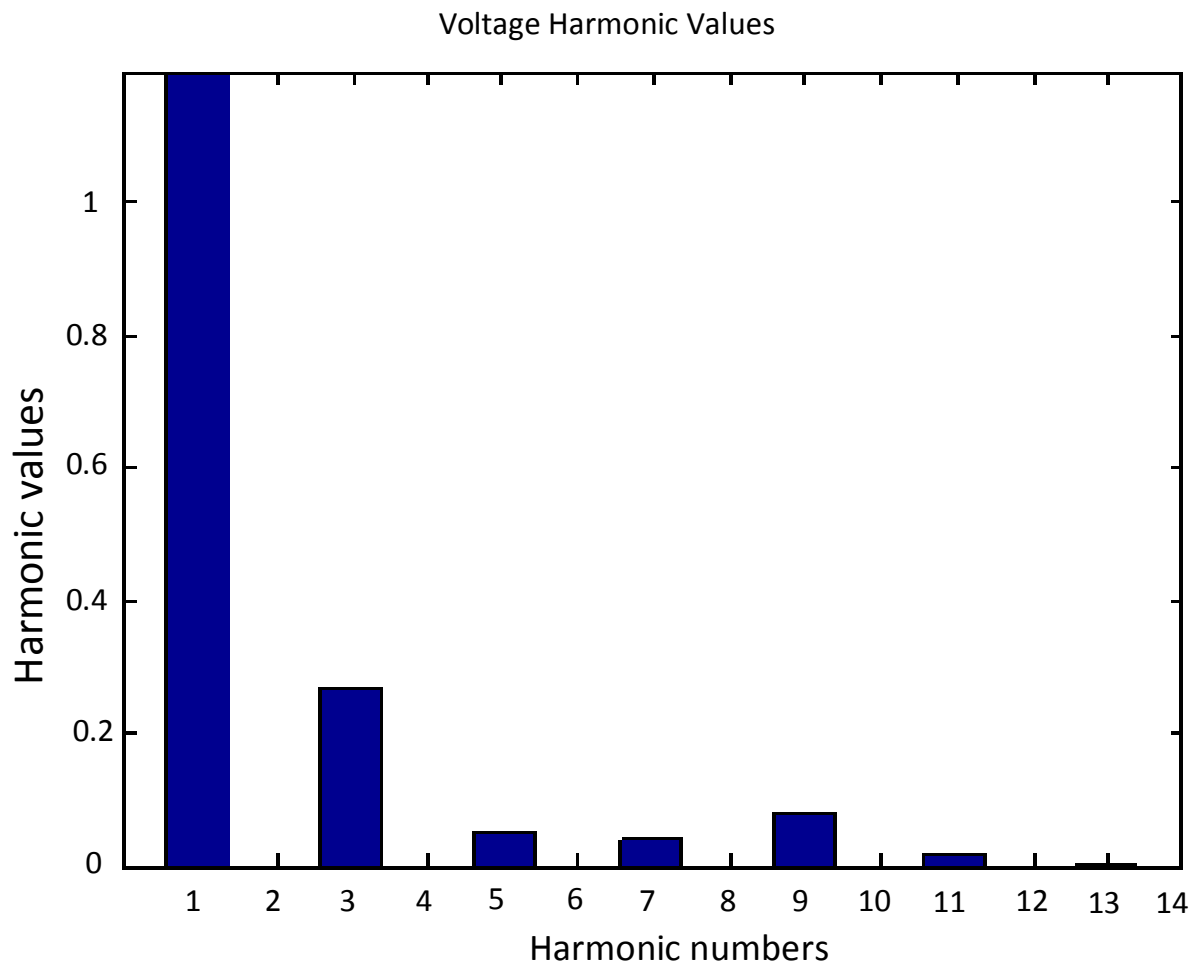

**Figure 8.** Standard harmonic distortion.

### Asynchronous motor model and current, angular speed, electromagnetic torque and harmonic distortion situations

Driver circuit is seen of 3-phase asynchronous motor obtained Matlab/Simulink environment. SPWM was obtained by comparison a triangle signal with 3-phase source in this circuit. Switching angles of the resulting PWM coming switching signal block are calculated with a program written in m-file. Finally our signal is converted to AC signal by 3-phase inverter and applied to asynchronous motor (figure 8-9 and in table 1).

### Simulation signals

Figure 10 displays 3-phase asynchronous motor stator current, angular speed and electromagnetic torque graphics that are obtained from the model prepared with

sinusoidal PWM by using GA found in Matlab Simulink environment. Figure 11 displays the graphic for voltage among phases are obtained from the model prepared with sinusoidal PWM by using GA found in Matlab Simulink environment. SPWM and GA output harmonic distortion are illustrated in figure 12 and 13 and in table 2 and 3.

### CONCLUSION

Inverters produce harmonics and they need to be optimized. The study proposes a GA-based method in the identification of the signal inducing angles required for the optimization of the magnetic performance of the asynchronous motors which is fed by three phase DGM inverter. It was seen from the simulation results that the method was successful in angular calculations. It was found according to the simulation results that the ASM



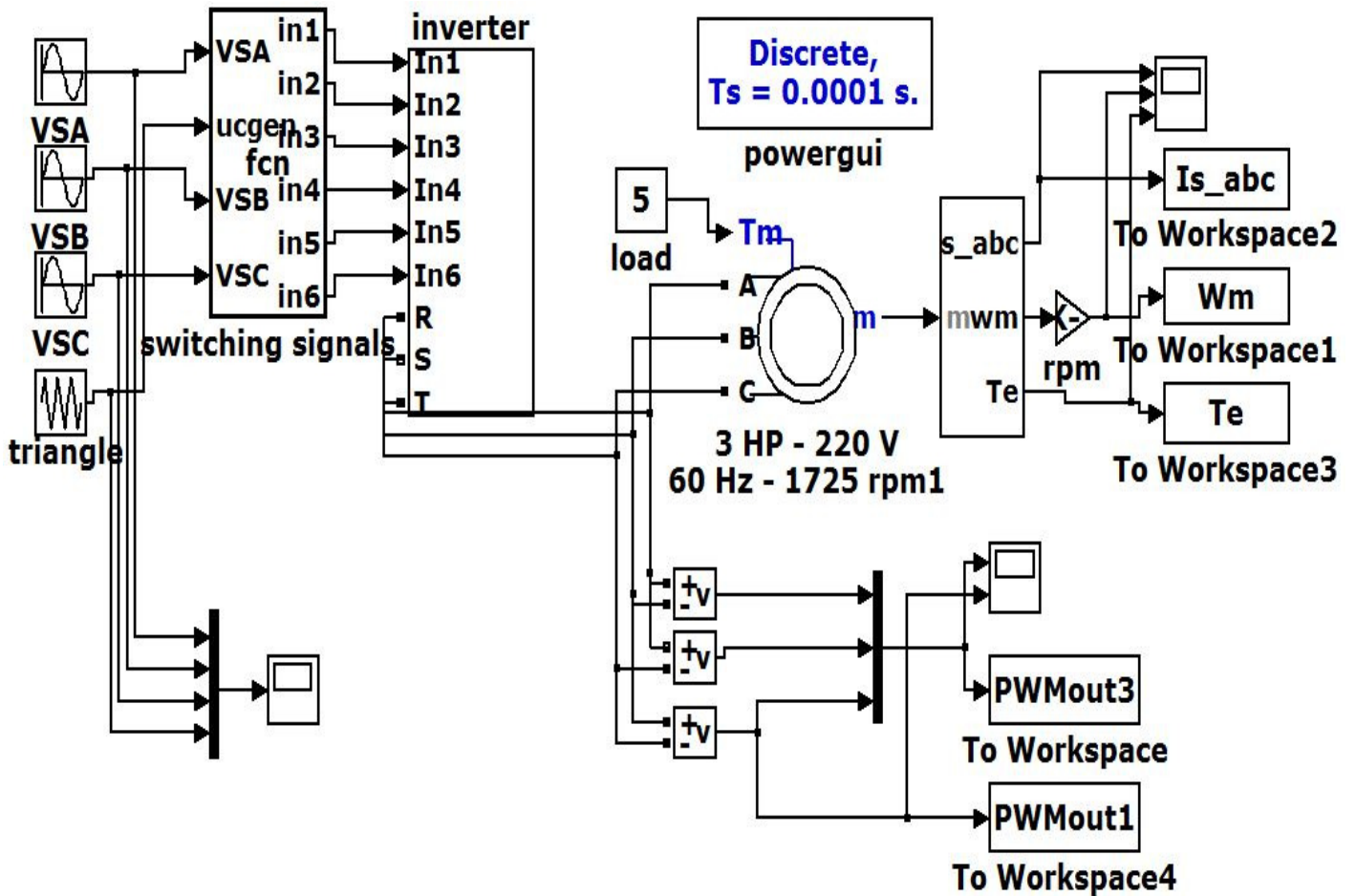

Figure 9. Newly created Matlab/Simulink model.

Table 1. Standard harmonic distortion values.

Harmonic degree	Harmonic value
1	1.2
3	0.27
5	0.05
7	0.04
9	0.08
11	0.019
13	0.005
15	0.049

voltage between phases fed by the inverter on which angles obtained by GA is applied, harmonics constituent voltage of phase current and THD in the inverter output current are all lower compared to the inverter in the newly created Simulink model. This has resulted in a more

efficient use of DC busbar voltage. Since the output voltage is higher, less current is needed for the power source which makes it possible to select lower current values for switching elements and to reduce switching losses.

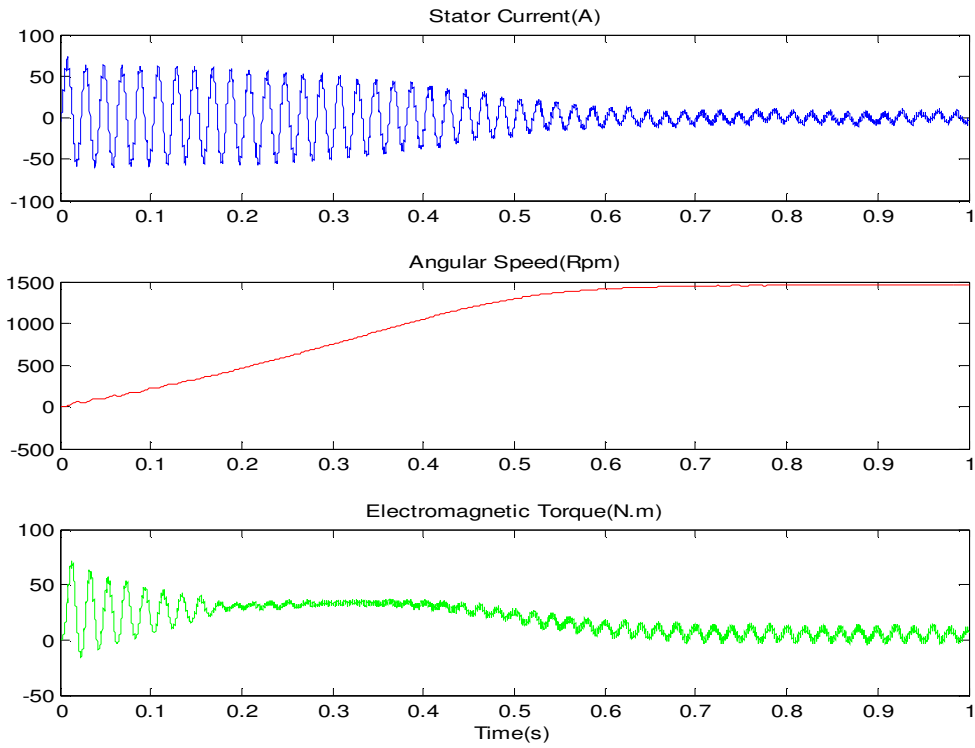

**Figure 10.** Three phase asynchronous motor stator current, angular speed and electromagnetic torque graphics.

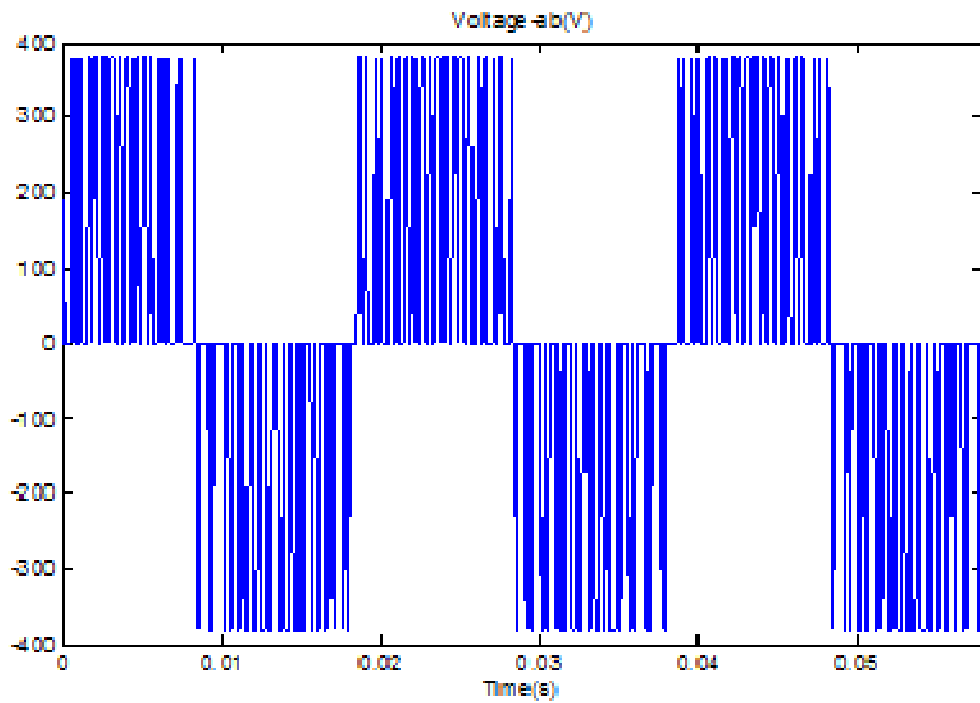

**Figure 11.** Phase to phase voltage of inverter.

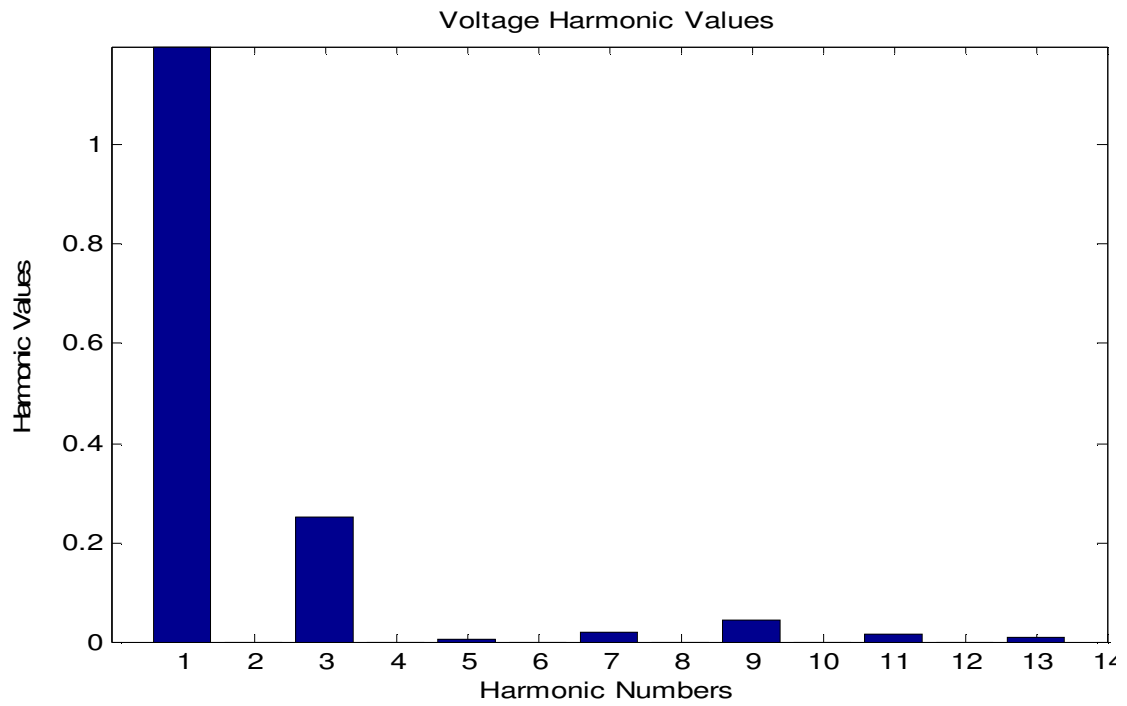

Figure 12. SPWM output harmonic distortion.

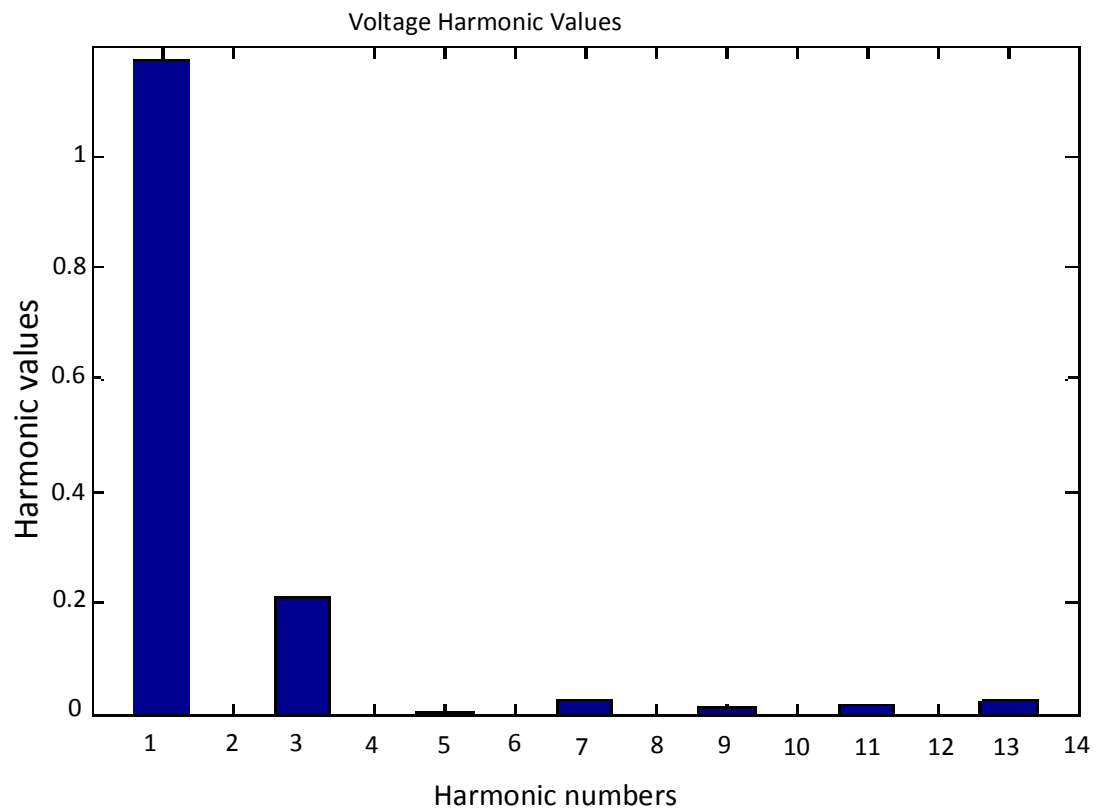

Figure 13. GA output harmonic distortion.

**Table 2.** SPWM output harmonic distortion.

Harmonic degree	Harmonic value
1	1.2
3	0.25
5	0.004
7	0.02
9	0.045
11	0.015
13	0.008
15	0.05

**Table 3.** GA output harmonic distortion values.

Harmonic degree	Harmonic value
1	1.18
3	0.21
5	0.0032
7	0.025
9	0.013
11	0.0145
13	0.022
15	0.051

## REFERENCES

- Antonio EG (2010). Transistor Diagnostic Strategies and Extended Operat. Under One-Transist. Trigger Suppress.in Invert. Power Drives. *IEEE Trans., Power Elect.*, 25(2): 499-505.
- Ashfaq A (1999). Power electronics for technology. Ohio: Printice Hall.
- Bellar MD, Wu TS, Tchamdjou A, Mahdavi J, Ehsani M (1998). A review of soft switched DC-AC converters. *IEEE Trans. Ind. Appl.*, 34(4): 847-860.
- Boduroglu T (1988). Elektrik Makinalari Dersleri: Teori, Hesap ve Konstruksiyon II. Istanbul, Beta.
- Bose BK (2002). Modern Power Electronics and AC Drives: Prentice Hall, New Jersey, pp. 191-200.
- Dugan RC (1994). Electrical Power Systems Quality: Mc Graw Hill Companies.
- Ertan HB, Akin E, Octug MY (1994). "Modern Electrical Drives" Springer, pp. 1-359.
- Gizolme O (1998). Shape Optimization of Synchronous Machine Rotor. *Int. J. Appl. Electromagnet. Mach.*, 9(3): 263-275.
- Goldberg DE (1989). Genetic Algorithms in Search: Optimis. and Mach. Learn. Addison Wesley Publish. USA.
- Gursu B (2002). Genetik Algoritmalar ile DC-AC ceviricilerde harmonik eliminasyonu, Yuksek lisans tezi, F.U. Elazig.
- Gursu B, Ince MC (2005). Finding Optimum Switching Angles on Harmonic Elimination Inverters by Genetic Algorithms. *J. Fen ve Muhendislik Bilimleri Dergisi: Uni. Firat.*, 17(2): 224-238.
- Hava AM, Kerkman RJ, Lipo TA (1999). Simple Analytical and Graphical Methods for Carrier-Based PWM-VSI Drives. Pp. 49-61.
- Holland JH (1992). Genetic Algorithms. *Sci. Am.*, pp. 66-72.
- Incekara B (2000). PWM Inverterlerin Incelenmesi, Yuksek Lisans Tezi, YTU: FBE Istanbul.
- Jeevananthan S, Dananjayan P, Venkatesan S (2005). A Novel Modified Carrier PWM Switching Strategy for Single-Phase Full-Bridge Invert, *Iran. J. Elec. Comp. Eng.*, 4(2): 101-108.
- Jeevananthan S, Nandhakumar R, Dananjayan P (2007). Inverted Sine Carrier for Fundament. Fortificat. in PWM Invert. and FPGA Based Implement. *Serbian J. Elect. Eng.*, 4(2): 171-187
- Karanun K, Khan-ngern W, Nitta S (2002). The Characteristics of Conducted EMI Emission on PWM Invert. with Various PWM Patterns, *IEEE*, pp. 533-536.
- Konuralp MS, Isik AH, Tacgin E (1998). Salinan Kol-Kizak Mekanizmalarin Kinematik Sentezini Genetik Algoritma Teknigi Kullanarak Gerceklestirilen Bir Prototip Yazilim. 8. Int. Congr. of Mech.Design and Manufactur.
- Mansfield RA (1990). Genetic Algorithms. University of Wales College of Cardiff.
- Nabiyev VV (2003). Yapay Zeka, Seckin Yayıncılık, Ankara.
- Sarioglu K (1983). Elektrik makinelerinin temelleri asenkron makineler. Caglayan Kitabevi, Istanbul.
- Sarioglu K (2003). Asenkron Motorlar ve Kontrolu. Birsen yayinlari, Istanbul.
- Sundvall J (2007). Dynamic Control of an Electrical Truck Motor. Alborg Univer.Inst. of Energy Technology.
- Mohan N, Undeland TM, Robbins WP (2003). Power Electronics: Converters, Applications and Design.
- Vithayathil J (1995). Power Electronics Principles and Applicat. McGrawhill Press, Newyork, pp. 218-255.
- Yedemale P (2005). AN 967-V/f Control of 3-phase induct. motors using PIC16F7X7 microcontrol.
- Yildiz C (2008). Genetik Algoritma Destekli Bulanik Denetim Kullanarak Vektor Esasli Asenkron Motor Kontrolu. Master thesis, Univers. of Kahramanmaraş Sutcu Imam, Kahramanmaraş, Turkey.
- Yumurtaci M (2007). Cesitli Modulasyon Tekniklerinin Harmonik Bozulma Uzerindeki Etkileri. Master thesis, Univers. of Afyonkocatepe, Afyon, Turkey.
- Zhou K, Wang D (2002). Relationship between Space- Vector Modulat. and Three-Phase Carrier-based PWM: A Compheren. *Anal. IEEE Trans. Ind. Elect.*, 49(1): 186-196.