

Review

Atmospheric pressure dielectric barrier discharge chemical and biological applications

N. N. Morgan

Physics Department, Faculty of Science (Male), Al -Azhar University, Nasr City, Cairo, Egypt. Email: nassernm_2000@yahoo.com.

Accepted 27 November, 2009

Recently atmospheric pressure dielectric barrier discharge (APDBD) plays an important role in chemical, industrial and biological applications. It has been used for ozone synthesis, hydrogen production from natural gas, surface treatment including textile and polymer treatment, yeast and bacterial inactivation. The physics and mechanism of atmospheric pressure dielectric barrier discharge will be reviewed. Coaxial and planar DBD have been constructed for ozone production, textile treatment and yeast sterilization. Oxygen has been used as working gas for ozone production, while oxygen and argon will be used for yeast inactivation.

Key words: Microdischarge, DBD, ozone, yeast sterilization.

INTRODUCTION

Dielectric barrier discharge (DBD), sometimes referred to as a barrier discharge or a silent discharge, is a type of discharge in which at least one of the electrodes is covered with a dielectric material. The dielectric layer acts as a current limiter and prevents the formation of a spark or an arc discharge. The electrical energy coupled into a DBD-plasma is mainly transferred to energetic electrons, while the neutral gas remains close to ambient temperatures. The non-equilibrium plasma that is produced in DBD system can be operated at elevated pressures. This combination of plasma properties makes it a unique device for many industrial applications (Kogelschatz, 2003; Kogelschatz et al., 1999). Traditional industrial applications range from ozone synthesis (Kogelschatz, 1988; Kogelschatz et al., 1995), pollution control (Penetrante et al., 1997; Rosocha, 1997), surface modification of textile and polymers (Linsley, 1980; Uehara, 1999). Nowadays, DBDs has found applications in plasma display panels, high-power CO₂ lasers (Kogelschatz, 2000) and excimer UV/VUV lamps (Elisson et al., 1988; Kogelschatz, 1990). New application in biology including bacterial inactivation (Morgan et al., 2009) and medicine are expected.

The aim of this paper is to review the mechanism of discharge of DBD and its chemical and biological applications. Two systems have been designed, coaxial one used for ozone production, pollution control and hydrogen production, parallel plate one that can be used for surface treatment including textile and polymer treatment, it has been used for yeast sterilization.

MECHANISM OF DISCHARGE

At atmospheric pressure, gases breakdown in a plane parallel gap with insulated electrodes normally occurs in a large number of individual tiny breakdown channels, referred to as micro-discharges (streamers) as shown in Figure 1.

An individual filamentary discharge is initiated when a high voltage is applied between the electrodes such that the electric field in the open gap equals or exceeds the breakdown strength of the ambient gas. The term "microdischarge" refers to a bright, thin plasma filament that is observed in DBD gap space. Electrons emission from the surface of the dielectric is stimulated by UV photoemission are accelerated in the electric field to energies that equal or exceed the ionization energy of the gas and create an avalanche in which the number of electrons doubles with each generation of ionizing collisions. The high mobility of the electrons compared to the ions allows the electrons to move across the gap in durations measured in nanoseconds. The electrons leave behind the slower ions and various excited and active species that may undergo further chemical reactions. When the electrons reach the opposite electrode, the electrons spread out over the insulating surface, counteracting the positive charge on the instantaneous anode. This factor, combined with the cloud of slower ions left behind, reduces the electric field in the vicinity of the filament and terminates any further ionization along the

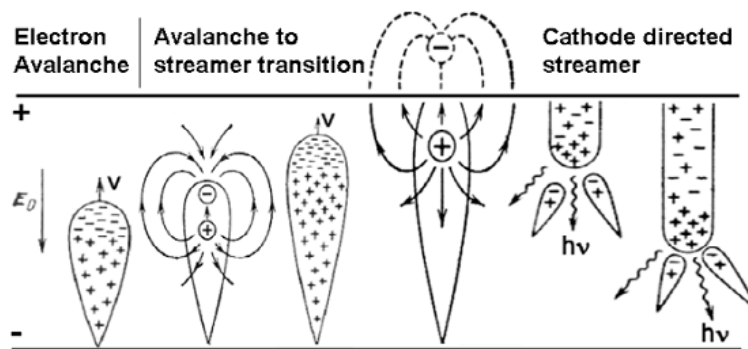

Figure 1. Microdischarge formation (Chirokov, 2005).

Table 1. Typical parameters for air discharges in a 1 mm gap.

Duration	$10^{-9} - 10^{-8}$ s	Total charge	$10^{-10} - 10^{-9}$ C
Filament radius	About 10^{-4} m	Electron density	$10^{20} - 10^{21}$ m $^{-3}$
Peak current	0.1 A	Mean electron energy	1 - 10 eV
Current density	$10^5 - 10^7$ Am $^{-2}$	Filament temperature	Close to average gas temperature in the gas

original track in time scales of tens of nanoseconds.

As a result thin conductive channels are formed inside the gap space between the electrodes (Braun et al., 1991; Braun et al., 1992). The deposition of electrons from the conducting channel into the anode dielectric barrier results in charge accumulation and prevents the formation of new avalanches and streamers nearby, until the cathode and anode are reversed. After the voltage polarity reverses, the deposited negative charge facilitates the formation of new avalanches and streamers in the same spot. As a result, many-generation family of streamers is formed that can be macroscopically observed as a microdischarge that appears to be spatially localized. Typical parameters for air discharges in a 1 mm gap are summarized in Table 1 (Kogelschatz, 2000).

CHEMICAL APPLICATIONS OF DBD

The early phases of micro discharge formation are characterized by electron multiplication, excitation and dissociation processes initiated by energetic electrons and by ionization processes and space charge accumulation. The ionic and excited atomic and molecular species initiate chemical reactions that finally result in the synthesis of a desired species (e.g., ozone, excimers,...) or the destruction of pollutants (e.g., volatile organic compounds (VOCs), nerve gases, odors, NH_3 , H_2S , NO_x , SO_2 , etc.). If the major reaction paths are dominated by charged particle reactions, the term plasma chemistry adequately describes the situation. In the majority of DBD applications, most charged particles disappear before any major changes occur. In this case it is most appropriate

to speak of a free-radical chemistry primarily involving neutral species like atoms, molecular fragments and excited molecules. The generated active species set the initial conditions for the ensuing chemical reactions. Typically, the first step is a dissociation of the initially molecular species by electron collisions. The dissociation of oxygen by electron impact can be highly efficient (up to 85% of the electron energy can be utilized for the dissociation process) corresponding to average electron energies of about 4 to 8 eV. This situation is unique in oxygen. In pure nitrogen the fraction of discharge energy spent on dissociation is much less due to energy lost for the excitation of vibrational levels. In CO_2 under favorable conditions, at most 40% of the electron energy can be utilized for the dissociation process. The efficiency of the different processes involved depends on their cross sections for electron collisions and the reduced field.

Ozone production

Ozone was first discovered by the European researcher C.F. Schonbein in 1839. It was first used commercially in 1907 in municipal water supply treatment in Nice and in 1910 in St. Petersburg (Alexander, 2008). Ozone (O_3), is a strong oxidizing agent made from stable molecular oxygen (O_2), replacing chlorinated compounds in a variety of applications including waste-water treatment (Gulyas et al., 1995), polluted air treatment and as a disinfectant. Ozone is unstable and decomposes slowly (in minutes) at ambient temperatures and rapidly (1s) at higher temperatures.

In order to generate ozone, a diatomic oxygen mole-

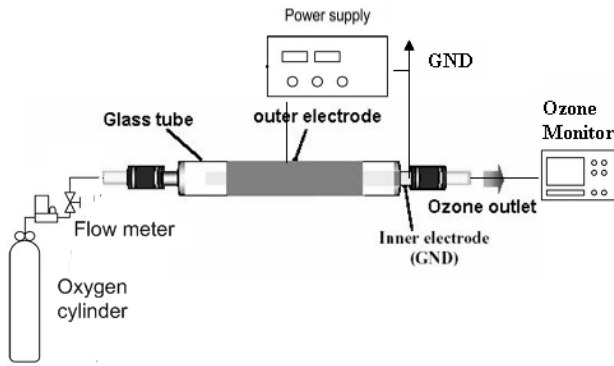

Figure 2. Schematic diagram for coaxial DBD used for ozone production Morgan N (2005).

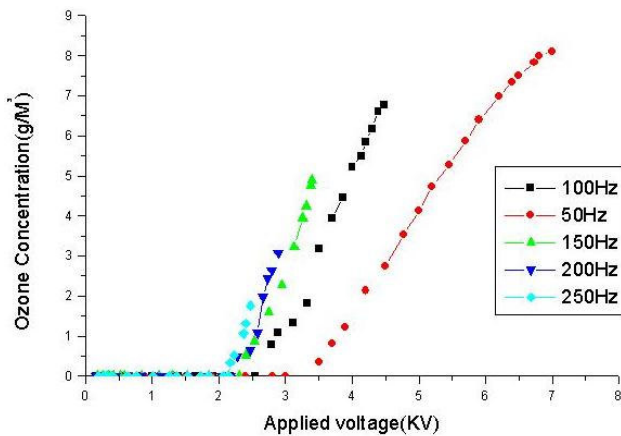
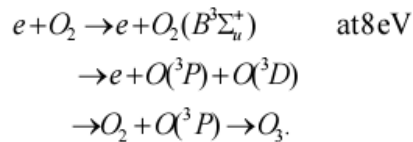
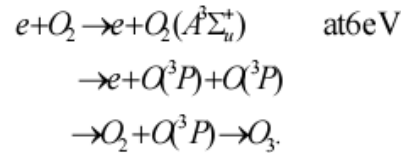

Figure 3. Ozone concentration with applied voltage at different frequencies Morgan N (2005)

molecule must first be split; the resulting oxygen free radical is thereby free to react with another diatomic oxygen to form the tri-atomic ozone molecule. However, in order to break the O–O bond a great deal of energy is required. Ultraviolet radiation (188 nm wavelength), corona discharge and DBD methods can be used to initiate free radical oxygen formation. Coaxial DBD ozone generator has been designed as shown in Figure 2 (Garamoon et al., 2002; Morgan, 2005). The ozone concentration has been measured using ozone detector (Model H1-AFX- Instrumentation, USA), which also measure the gas flow rate Figure 3 shows the relation between the applied voltage (in kV) and ozone concentration at constant flow rate at different applied frequency..

The behavior between the applied voltage and ozone concentration at constant flow rate be explained as follow, at first no ozone is detected, since the applied voltage has not reached a high enough value for the gas breakdown to occur. Increasing applied voltage, breakdown in oxygen takes place and dissociation of oxygen molecules occurs, producing atomic oxygen that recom-

binates with oxygen molecules to produce ozone and hence the ozone detected. The ozone concentration can be noticed to increase at slow rate, up to certain voltage and then it tends to increase at a higher rate. According to eliasson et al. (1987), Murphy et al. (2001) and Morent et al. (2001), ozone being produced in pure oxygen through two different mechanisms:



First mechanism Second mechanism

It is believed that ozone is generated at a slow rate by the first reaction, while it is generated by both reactions in high rate region. This explains the enhancement of the rate of ozone generation. With more increase of the applied voltage ozone concentration tends to slow down, that can be attributed to several reasons that can be summarized as follows:

1- Ozone can be destroyed through collision with electron and atomic oxygen according to the reaction:

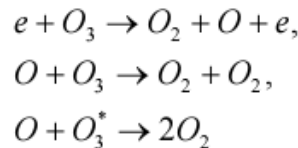

2- Self-emitted light (200 - 300 nm) in the oxygen discharge can cause the ozone to be dissociated through photo-dissociation reactions (Mordonich et al., 1992).

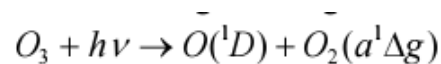

3- The amount of energy dissipated in microdischarge at high applied voltage leads to a minute instantaneous local temperature rise, which may cause a significant dissociation of the ozone molecules.

Hydrogen production

Hydrogen is supposed to play an important role in the worldwide energy supply. It allows a more efficient utilization of fossil fuels and the reduction of noxious emissions by using hydrogen fuel cells or the hydrogen enriched

fuels in combustion engines or gas turbines. Plasma methods are expected to allow low temperature and fuel flexible on-site hydrogen generation.

Experiments on methane steam reforming for hydrogen generation with a dielectric barrier discharge (DBD) reactor were performed. Methane or natural gas reforming is widely used in industry to obtain hydrogen or synthesis gas ($H_2 + CO$), which are utilized in industry for as source materials for the production of raw chemicals like methanol and ammonia, hydrogenation agents in oil refinery and as reducing gases in steel industry. The main reaction in steam reforming of methane is the oxidation with steam, yielding a mixture of hydrogen and carbon monoxide:

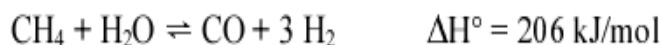

This strong endothermic reaction is industrially carried out using a nickel based catalyst at about 800°C and 25 bar. To further increase the hydrogen yield and to remove carbon monoxide from the product gas, the exothermic water shift reaction can be applied in an additional stage at temperatures between 190 and 260°C over a copper-zinc based catalyst.



Plasma-induced steam reforming has been investigated before by using thermal arc discharge (Bromberg et al., 1998) or microwave discharge (Jasiński, 2008). Some recent publications discuss the influence of dielectric barrier discharges on pure methane (Mfopapa et al., 2008), mixtures of methane with air (Horng et al., 2007) and aim mainly on the production of methanol or higher hydrocarbons (Aghamir et al., 2004).

Pollution control

An increasing number of investigation have been devoted to the reduction of nitrogen oxides (NO_x) in automotive diesel exhaust and sulphur oxides (SO_x) and to the decomposition of volatile organic compounds (VOCs) like hydrocarbons, chlorofluorocarbons and other hazards air pollutants using DBD (Rudolph et al., 2002; Yamagata et al., 2006). The principles which are behind the destruction of pollutants with non thermal plasma like DBDs may be understood based on the fact that energetic electrons inside the plasma can activate gas molecules by collision processes different and subsequently initiate a number of reactions generating free radicals O, OH, HO_2 for decomposing pollutants. Oxidation is the main process in reducing exhausts containing dilute concentration of pollutants (NO , VOC) in mixture of N_2 and O_2 . In humid gas mixture the formation of OH radicals result in the formation of HNO_2 and HNO_3 by reaction with NO and

NO_2 .

BIOLOGICAL APPLICATIONS OF DBD

The recent trends focus on using plasmas in the health care for "processing" of medical equipment and even living tissues. The major goal of tissue treatment with plasmas is non-destructive surgery, controlled, high-precision removal of diseased sections with minimum damage to the organism. Furthermore, plasmas allow fast and efficient bacterial inactivation, which makes them suitable for sterilization of surgical tools and local disinfecting of tissues. Much research effort must be undertaken before these techniques will become common in medicine, but it is expected that a novel approach to surgery will emerge from plasma science. An extremely promising field will be the plasma-based treatment of chronic wounds. A selective antimicrobial (antiseptic) activity without damaging surrounding tissue, combined with a controlled stimulation of tissue regeneration could revolutionize wound care. Other fields are the treatment of skin diseases (Vasilets et al., 2009) and tissue engineering (Fridman et al., 2008)

Yeast and bacterial strilization

Broad spectrums of microorganisms are susceptible to plasma exposure, including gram-negative and gram-positive bacteria (Guimin et al., 2009), bacterial endospores (Moisan et al., 2001), yeasts (Morgan et al., 2009), viruses (Moisan et al., 2001) and bio-films (Salamitou et al., 2009). Bacterial deactivation is accompanied by the leakage of proteins, deoxyribonucleic acid (DNA) and ribonucleic acid (RNA) from the cellular cytoplasm (Moisan et al., 2001). There are two main hypotheses for the mechanisms of cell death caused by gas discharge. Both mechanisms involve lethal damage to cell membrane structures and ultimately lead to leakage of cytoplasmic contents or lyses. Firstly, the electrostatic disruption mechanism suggests that the total electric force caused by accumulation of surface charge could exceed the total tensile force on the membrane. Secondly, an oxidation mechanism, which causes damage of the cell membrane or cellular components, is suggested to be caused by energetic ions, radicals and reactive species generated by the gas discharge. The survivor curve, that is, the number of colony forming units (CFU) versus treatment time, is used to study the plasma deactivation kinetics. From this curve the decimal value (D-value), which is defined as the time required to reduce the original concentration of microorganisms by 90%, can be found. The D-value is a parameter through which the efficiency of the interaction process can be measured and it is expressed in the unit of time. A planar DBD shown in Figure 4 has been designed for yeast sterilization and described elsewhere (Morgan et al., 2009).

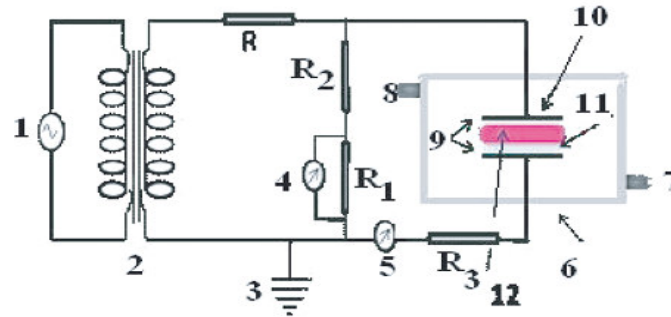

Figure 4. Experimental setup for yeast sterilization, 1 is the main (220 V, 50 Hz); 2 is the high voltage transformer; 3 is the earth; 4 is the a.c. voltmeter; 5 is the a.c. current meter; 6 is an air-tight plexiglass box; 7 is the gas-in-port; 8 is the gas out- port; 9 are the dielectric plates (glass); 10 are the stainless steel electrodes; 11 is the yeast-glass slide; 12 is the produced plasma (Morgan, 2009).

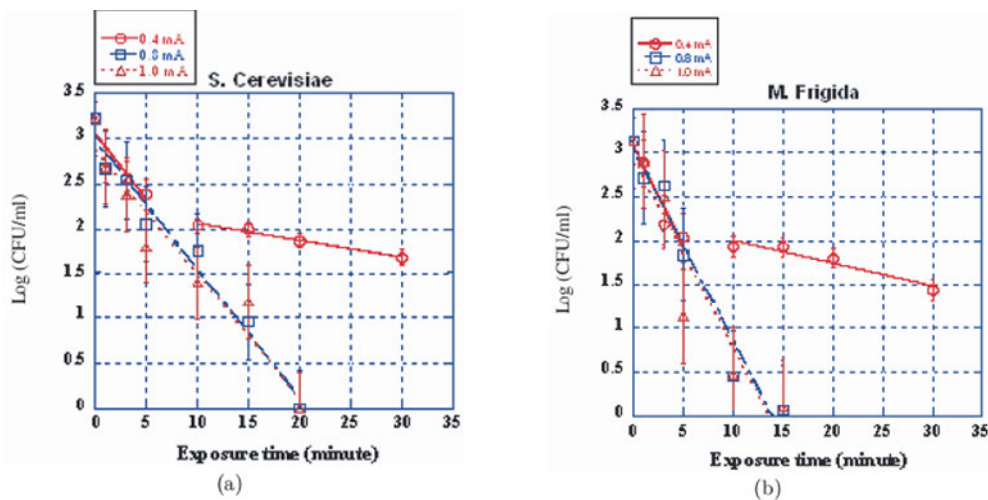

Figure 5. (a) *S. Cerevisiae* and (b) *M. Frigida* deactivated by argon DBD discharge (Morgan, 2009).

S. Cerevisiae and *M. Frigida* were isolated and cultivated in an YM broth medium. Sterilized slides were immersed in these solutions to form a thin film of the desired yeast on it. One slide of each yeast was kept as a control sample. The other slides were inserted between the two electrodes of the DBD system. The slides were exposed to argon and oxygen plasmas separately for different exposure times and under different discharge currents, at gas flow rate of 5 L/min. The treated slides were then preserved in a YM agar medium poured into sterilized Petri dishes, followed by the addition of 0.1 ml of saline solution (6 g/L) to uniformly distribute the treated yeast cells in the dishes. The total viable count method was used to compare the control and plasma-treated samples. The survivor curves in Figures 5a and b were fitted by single straight lines for discharge currents of 0.8 and 1.0 mA. From these fits, the deactivation of both of *S. Cerevisiae* and *M. frigida* using argon plasma with dis-

charge currents of 0.8 and 1.0 mA were almost the same. D-values of 7 and 4.7 min were calculated from the linear fits for *S. Cerevisiae* and *M. Frigida*, respectively. *S. Cerevisiae* and *M. Frigida* were deactivated using DBD discharge operated by oxygen at discharge current of 0.4, 0.8 and 1.0 mA. The survivor curves of *S. Cerevisiae* and *M. Frigida* are shown in Figures 6a and b respectively. The total deactivation times of *S. Cerevisia* and *M. Frigida* were equal for the same discharge current 15 and 10 min at discharge currents of 0.8 and 1.0 mA respectively. It should be mentioned here that complete deactivation of *S. Cerevisiae* and *M. Frigida* could not be achieved for exposure time of 30 min and a discharge current of 0.4 mA.

Some mechanisms for the deactivation of microorganisms by low-temperature plasma have been explained and discussed elsewhere (Moisan et al., 2001). Some researchers mentioned that heat and the high UV radi-

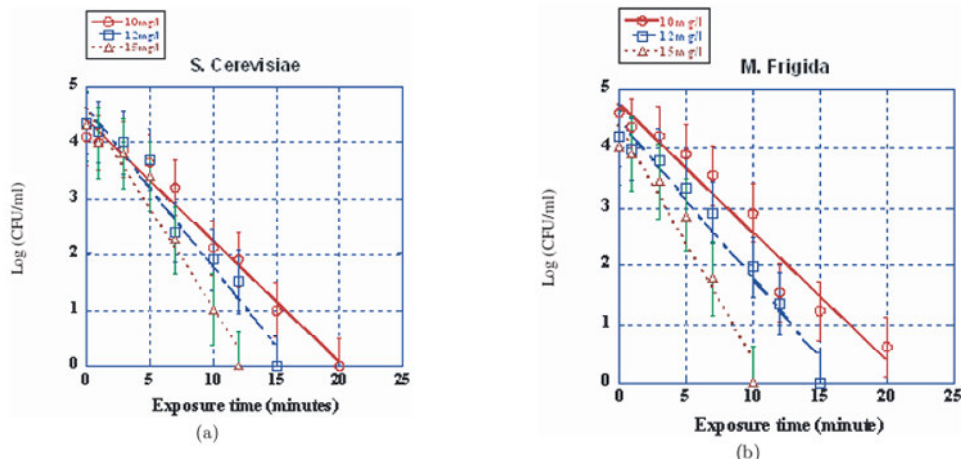

Figure 6. (a) *S. Cerevisiae* and (b) *M. Frigida* deactivated by oxygen DBD (Morgan, 2009).

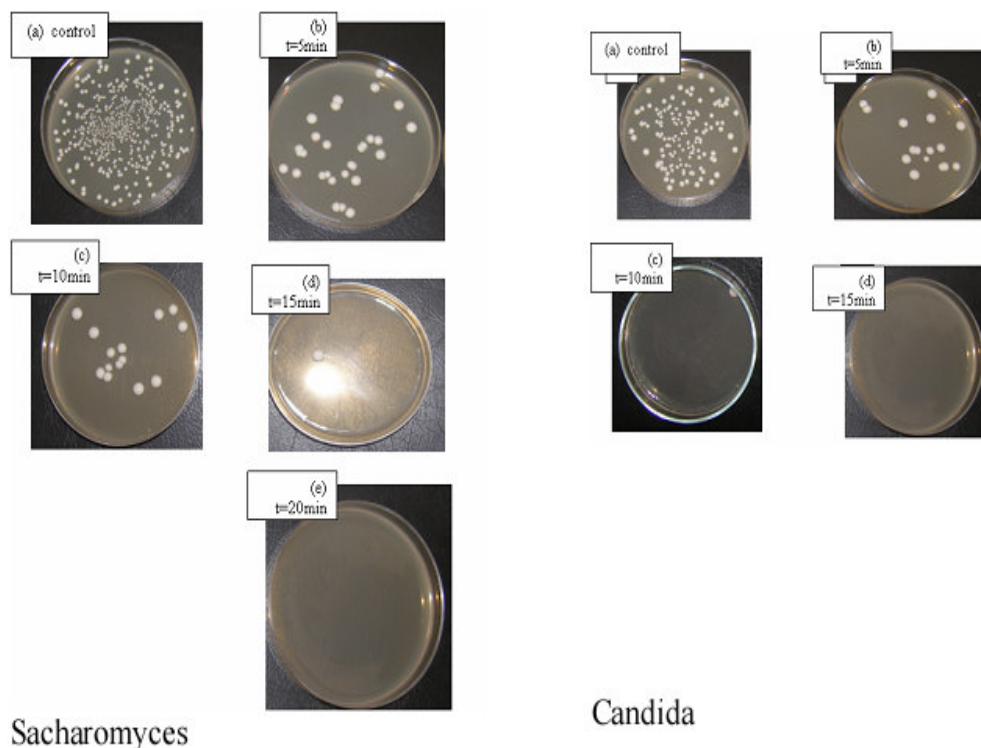

Figure 7. Image of *Sacharomyces* and *Candida* yeast at different sterilization condition with the control as an untreated yeast.

tion effect on microorganisms play a major role during the deactivation (Laroussi, 2004). On the other hand, other researchers have commented that chemical reactions with the active free radicals (electrons, O_2^+ , O , O^+) and ozone present in the plasma play a major role during the deactivation process (Maisch, 2007). Other workers believe that the physical processes caused by positive and negative ions (O^+ , O^- and Ar^+) in the discharge stream are also important for deactivation. Ozone formed in oxygen plasma plays a major role in the deactivation of

the yeast. A photograph for the yeast cells in Petri dish before and after treatment at different exposure time in oxygen plasma at discharge current of 1 mA is shown in Figure 7 which insure the inactivation of the yeast by oxygen plasma.

Scanning electron microscope (JSM-5600LV) was used to study the morphology of the yeast cell surface after and before plasma treatment that shows rupture in the cell surface after treatment which insure the inactivation of the yeast as a result of plasma treatment (Figure 8).

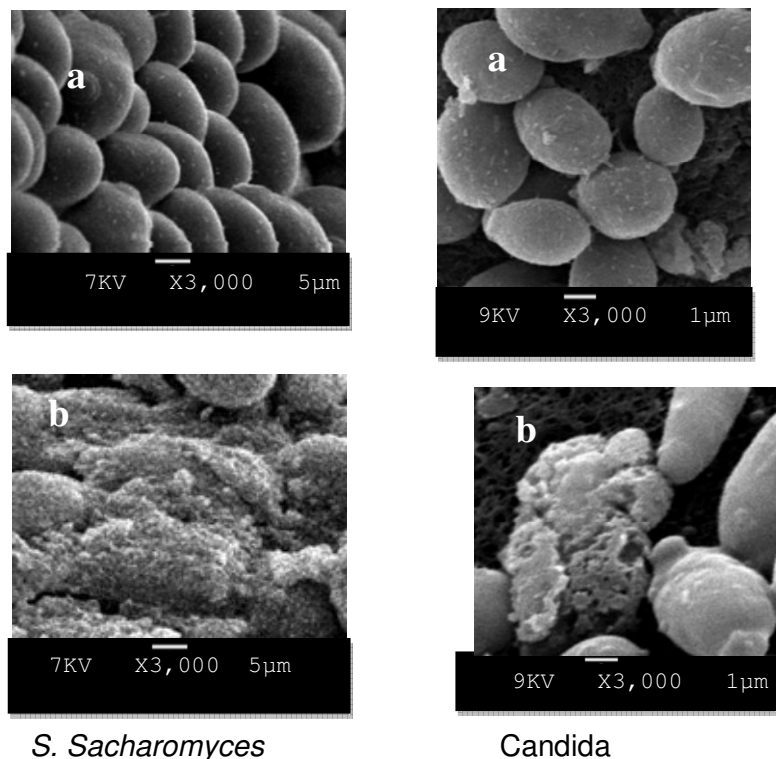

Figure 8. SEM of *Sacharomyces* and *Candida* yeast (a) Before treatment (b) After treatment

REFERENCES

- Aghamir F, Matin N, Jalili A, Esfarayeni M, Khodagholi M, Ahmadi R (2004). Conversion of methane to methanol in an ac dielectric barrier discharge Plasma Sources Sci. Technol. 13: 707-711.
- Alexander F (2008). Plasma Chemistry Cambridge University Press, New York 382p.
- Braun D, Gibalov V, Pietsch G (1992). Two-dimensional modelling of the dielectric barrier discharge in air Plasma Sources Sci. Technol. 1: 166-172.
- Braun D, K uchler U, Pietsch G (1991). Microdischarges in air-fed ozonizers J. Phys. D: Appl. Phys. 24: 564-572.
- Bromberg L, Cohn DR, Rabinovich A (1998). Plasma Reforming of Methane, Energy Fuels 12: 11-18.
- Chirokov A, Gutsol A, Fridman A (2005). Atmospheric pressure plasma of dielectric barrier discharges Pure Appl. Chem. 77(2): 487-495.
- Eliasson B, Hirth M, Kogelschatz U (1987). Ozone synthesis from oxygen in dielectric barrier discharges J. Phys. D: Appl. Phys. 20: 1421-1437.
- Eliasson B, Kogelschatz U (1988). UV excimer radiation from dielectric-barrier discharges Appl. Phys. B 46: 299-303.
- Fridman G, Friedman G, Gutsol A, Shekhter A, Vasilets V, Fridman A (2008). Appl. Plasma Med. Plasma Process. Polym. 5(6): 503 - 533.
- Garamoon A, Elakshar F, Nossair A, Kotb E (2002). Plasma Sources Sci. Technol. 11: 254-259.
- Guimin X, GuanJun Z, Xingmin S, Yue¹ M, Ning W, Yuan L (2009). Bacteria Inactivation Using DBD Plasma Jet in Atmospheric Pressure Argon Plasma Sci. Technol. 11: 83-88.
- Gulyas H, von Bismarck R, Hemmerling L (1995). Treatment of Industrial wastewaters with ozone/hydrogen peroxide Water Sci. Technol. 32(7): 127-134.
- Horng R, Chang Y, Huang H, Lai M (2007). A study of the hydrogen production from a small plasma converter Fuel 86(1-2): 81-89.
- Jasiński M, Dors M, Mizeraczyk J (2008). Production of hydrogen via methane reforming using atmospheric pressure microwave plasma. J. Power Sources 181(1-15): 41-45.
- Kogelschatz U (1990). Silent discharges for the generation of ultraviolet and vacuum ultraviolet excimer radiation Pure Appl. Chem. 62: 1667-1674.
- Kogelschatz U (2000). Physics and applications of dielectric-barrier discharges The 27th IEEE International Conference on Plasma Science 81p.
- Kogelschatz U (2003). Dielectric-barrier Discharges: Their History, Discharge Physics, and Industrial Applications Plasma Chemistry and Plasma Processing 23: 1-46.
- Kogelschatz U (1988). Advanced Ozone Generation, in: Process Technologies for Water Treatment, S. Stucki (Ed.), Plenum Press, New York pp. 87-120.
- Kogelschatz U, Eliasson B (1995). Ozone Generation and Applications, in: Handbook of Electrostatic Processes, Chang JS, Kelly AJ, Crowley JM (Eds.), Marcel Dekker, New York pp. 581-605.
- Kogelschatz U, Eliasson B, Egli W (1999). From ozone generators to flat television screens: history and future potential of dielectric-barrier discharges Pure Appl. Chem., Vol. 71(10): 1819-1828.
- Laroussi M, Leipold F (2004). Evaluation of the roles of reactive species, heat, and UV radiation in the inactivation of bacterial cells by air plasmas at atmospheric pressure International J. Mass Spectrom. 233(1-3): 81-86.
- Madronich S, Granier C (1992). Impact of recent total ozone changes on tropospheric ozone photodissociation, hydroxyl radicals, and methane trends Geophys. Res. Lett. 19: 465-467.
- Maisch T, Baier J, Franz B, Maier M, Landthaler M (2007). The role of singlet oxygen and oxygen concentration in photodynamic inactivation of bacteria Proc. Natl. Acad. Sci. USA, 104: 7223-7228.
- Mfopara A, Michael K, Odic E (2008). Dilute Methane Treatment by Atmospheric Pressure Dielectric Barrier Discharge: Effects of Water Vapor Plasma Chemistry and Plasma Processing Vol. 29(2): 91-102.
- Moisan M, Barbeau J, Moreau S, Pelletier J, Tabrizian M, Yahia L (2001). Low-temperature sterilization using gas plasmas: a review of the experiments and an analysis of the inactivation mechanisms. Int.

- J. Pharm. 226(1-2): 1-21.
- Morent R, Callebaut T, Loys C (2001). Study of ozone production in a DC-excited multi-pin-to-plate plasma source International symposium on plasma chemistry (Orleans, France) vol II p 3097.
- Morgan N (2009). Elsabbagh M, Desoky S and Garamoon A Deactivation of yeast by dielectric barrier discharge. Eur. Phys. J. Appl. Phys. 46: 3-31001.
- Morgan N (2005). Frequency Optimization of Coaxial DBD Ozone Generator Al Azhar Bulletin of basic science vol. 16(2): 49-56.
- Murphy A, Morrow R (2001). An experimental assessment of glass-bead discharge ozonisers International symposium on plasma chemistry (Orleans, France) 2: 3103.
- Rosocha L, Manheimer W, Sugiyama L, (1997). Plasma Science and the Environment American Institute of Physics, Woodbury, New York pp.261-298.
- Rudolph R, Francke K, Miessner H (2002). Concentration Dependence of VOC Decomposition by Dielectric Barrier Discharges. Plasma Chem. Plasma Process. 22: 3-401.
- Penetrante M, Bardsley J, Hsiao M (1997). Jpn. J. Appl. Phys. 36: 5007-5017.
- Salamitou S, Kirkpatrick M, Ly H, Leblon G, Odic E, DuBow M (2009). Augmented Survival of Bacteria Within Biofilms to Exposure to an Atmospheric Pressure Non-Thermal plasma source. Biotechnology 8(2): 228-234.
- Vasilets V, Gutsol A, Shekhter A, Fridman A (2009). Plasma medicine. Plasma Chem. 43(3): 229-233.
- Yamagata Y, Niho K, Inoue K, Okano H, Muraoka K (2006). Decomposition of Volatile Organic Compounds at Low Concentrations Using Combination of Densification by Zeolite Adsorption and Dielectric Barrier Discharge Jpn. J. Appl. Phys. 45: 8251-8254.